

MULTI-FAMILY RESIDENTIAL PROJECT

505 MAIN STREET
STURBRIDGE, MA 01518

SHEET INDEX

No.	Title	Issue Date
C001	Cover Sheet	December 22, 2022
C101	Site Demo & Sediment and Erosion Control Plan	December 22, 2022
C102	Layout Plan	December 22, 2022
C103	Grading & Drainage Plan	December 22, 2022
C501	Site Details - 1	December 22, 2022
C502	Site Details - 2	December 22, 2022

REFERENCE PLAN INDEX

No.	Title	Issue Date
-	Boundary & Topographic Survey (Levesque Geomatics Inc.)	October 27, 2022

REVISIONS/ISSUES

No.	Note	Date
1	Issued for Permitting	December 22, 2022
2	Issued for Permitting	November 3, 2023

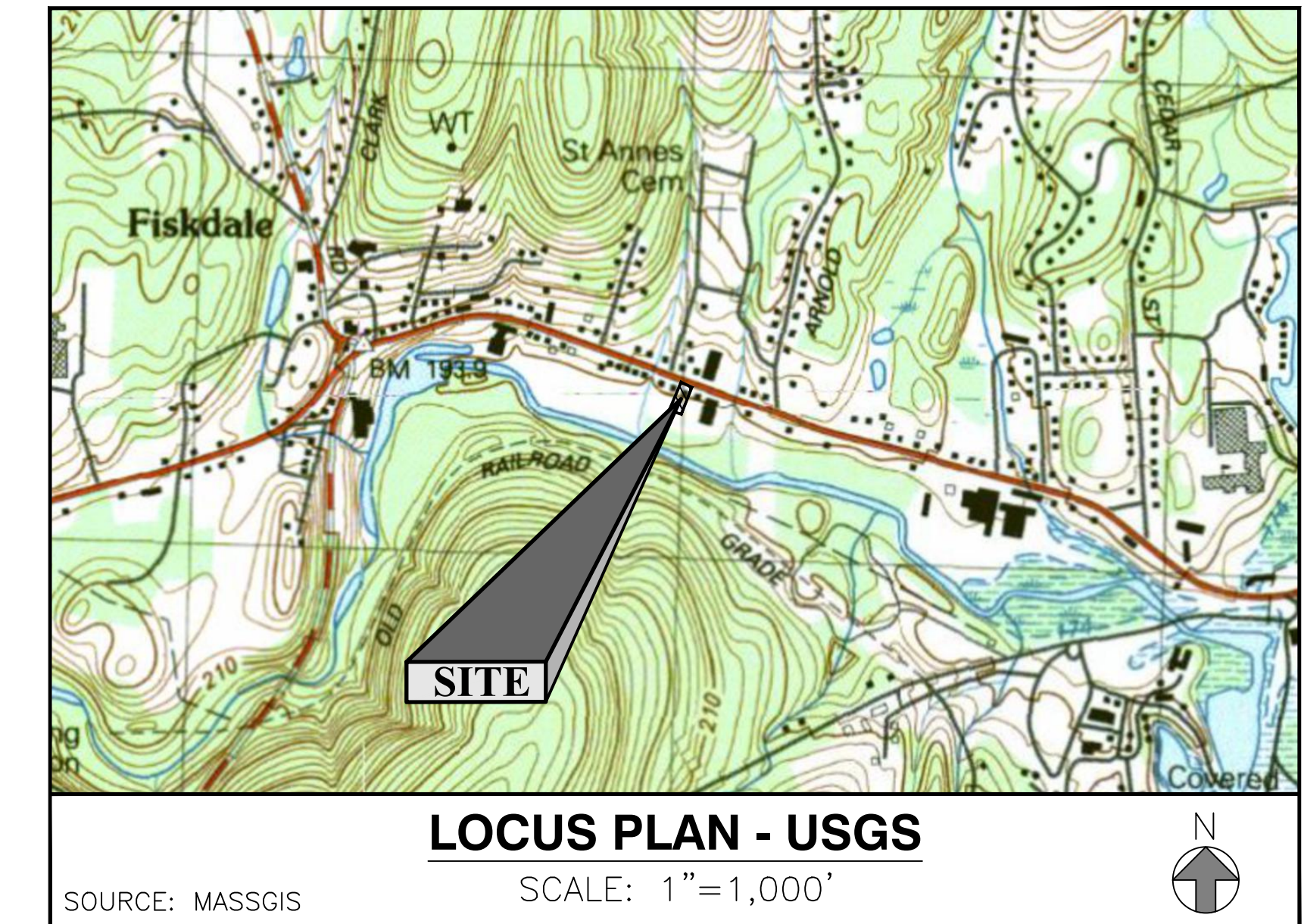
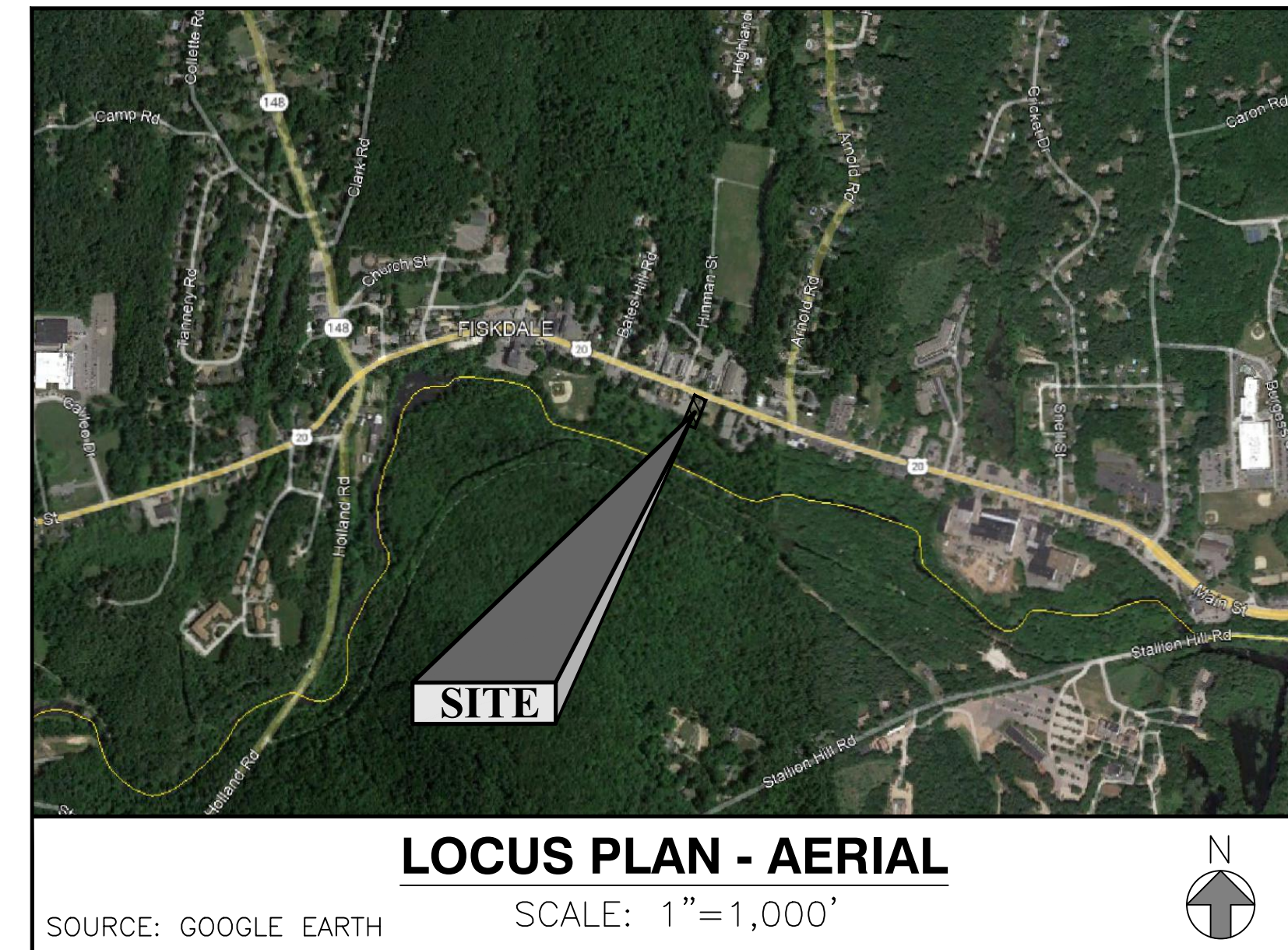

OWNER
Jenny Bounphasaysonh
126 Southbridge Road
Dudley, MA 01571

ENVIRONMENTAL CONSULTANT
EcoTec, Inc.
102 Grove Street
Worcester, MA 01605

APPLICANT
STL Group, LLC
P.O. Box 638
Sturbridge, MA 01566

SURVEYOR
Levesque Geomatics Inc.
43 Glendale Road
Sturbridge, MA 01518



100 GROVE STREET | WORCESTER MA 01605
T 508-856-0321 | F 508-856-0357
gravesengineering.com

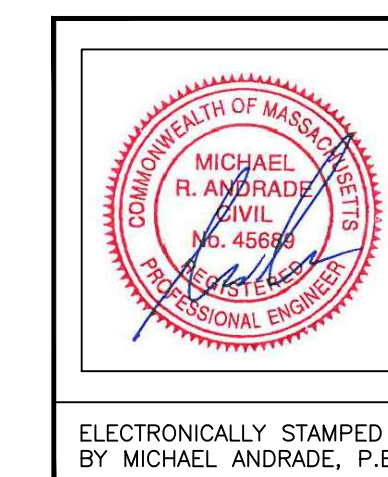

GENERAL NOTES

PARCEL DATA:
STREET ADDRESS: 505 MAIN STREET, STURBRIDGE, MA 01518

AREA: ±16,466 SQ. FT. (0.378 AC.)

OWNER: JENNY BOUNPHASAYSONH ZONE: COMMERCIAL TOURIST DISTRICT
126 SOUTHBRIDGE ROAD OVERLAY: ZONE II WELLHEAD PROTECTION AREA
DUDLEY, MA 01571

- NOTES:
- 1) THIS PLAN WAS PREPARED WITHOUT THE BENEFIT OF A TITLE REPORT AND IS SUBJECT TO ANY FINDINGS SUCH A REPORT MIGHT DISCLOSE.
 - 2) LOCATION OF UNDERGROUND UTILITIES SHOWN HEREON ARE APPROXIMATE AND ARE BASED ON THE FIELD LOCATION OF VISIBLE STRUCTURES SUCH AS CATCH BASINS, MANHOLES, WATER GATES, ETC. IN ACCORDANCE WITH CHAPTER 82 SECTION 40 INCLUDING AMENDMENTS. ALL CONTRACTORS SHOULD NOTIFY IN WRITING ALL UTILITY COMPANIES AND GOVERNMENT AGENCIES PRIOR TO ANY EXCAVATION WORK AND CALL DIG-SAFE AT 811. THE TOWN OF STURBRIDGE SHALL ALSO BE CONTACTED FOR UTILITY MARKOUTS.
 - 3) PROPERTY LINE DATA AND TOPOGRAPHIC FEATURES ON THIS PLAN ARE BASED ON PLAN PREPARED BY LEVESQUE GEOMATICS INC., DATED OCTOBER 27, 2022.
 - 4) THE VERTICAL DATUM FOR THIS PROJECT IS NAVD 88. HORIZONTAL DATUM IS MASSACHUSETTS STATE PLANE COORDINATE SYSTEM. DATUMS ARE AS ESTABLISHED BY GPS METHODS.
 - 5) THE SITE PROPERTY IS NOT LOCATED WITHIN ANY DESIGNATION FLOOD ZONES AS SHOWN ON FIRM MAP 25027C0926E, DATED JULY 4, 2011.
 - 6) RESOURCE AREA BOUNDARY WAS DELINEATED BY ECOTEC, INC. ON NOVEMBER 3, 2022.

REFERENCES:
DEED BOOK/PAGE: 47562/345 (WORCESTER REGISTRY OF DEEDS)
ASSESSORS REFERENCE: 415-02432-505

SHEET KEY

- FEATURES MARKED AS SHALL BE PROTECTED
FEATURES MARKED AS SHALL BE R&D
R&D = REMOVE AND DISPOSE (OFFSITE)
////// = R&D FEATURE



Know what's below.
Call before you dig.

LEGEND

- UNDERGROUND ELECTRIC
- GAS
- DRAIN
- SEWER
- WATER
- SEWER MANHOLE (SMH)
- CATCH BASIN (CB)
- WATER GATE VALVE
- HYDRANT
- LIGHT POLE
- SOLID FENCE
- GUARDRAIL
- TREE LINE
- BITUMINOUS PAVEMENT (BIT.)
- CONCRETE (CONC.)
- TREE, SIZE, DECIDUOUS (DEC.), CONIFEROUS (CON.)
- HAY BALES & SILT FENCE
- STRAW WATTLES & SILT FENCE
- INV. INVERT
- SPOT ELEVATION
- NEW PAVEMENT AREA
- GENERAL DIRECTION OF RUNOFF
- EOP EDGE OF PAVEMENT
- M.E. MATCH EXISTING (ELEVATION)
- H.P. HIGH POINT (ELEVATION)
- L.P. LOW POINT (ELEVATION)
- WF-# WETLAND RESOURCE AREA FLAG-NO.
- W200 200-FOOT BUFFER ZONE (LOCAL)
- W100 100-FOOT BUFFER ZONE
- W50 50-FOOT BUFFER ZONE (LOCAL)
- W25 25-FOOT BUFFER ZONE (LOCAL)

SHEET NOTES

- 1) ALL EXISTING PAVEMENT ABUTTING NEW PAVEMENT SHALL BE NEATLY SAWCUT.
- 2) ALL ITEMS NOTED TO BE REMOVED AND DISPOSED SHALL BE PROPERLY DISPOSED OF OFFSITE.
- 3) STOCKPILE LOCATIONS (FILL MATERIALS, ETC.) SHALL BE COORDINATED WITH THE OWNER AND THE ENGINEER AND SHALL BE RINGED WITH SILT FENCE. ALL DISTURBED AREAS INCLUDING STOCKPILES, THAT WILL NOT BE RE-DISTURBED WITHIN 14 DAYS SHALL BE STABILIZED BY THE 14TH DAY AFTER THE LAST DISTURBANCE.
- 4) THE CONTRACTOR SHALL EMPLOY ANY AND ALL EROSION AND SEDIMENT CONTROL MEASURES TO PREVENT A RELEASE OF SEDIMENT FROM THE SITE.
- 5) SEDIMENT AND EROSION CONTROLS SHALL BE INSTALLED PRIOR TO THE START OF ANY SITE WORK.
- 6) SEDIMENT TRACKED ONTO ROADWAYS ADJACENT TO THE SITE SHALL BE SWEEPED CLEAN AND REMOVED EACH DAY.

MAP 2432
LOT 507
N/F LANDS OF
ADVANT & BAPTISTE SOCIETY
(DEED NOT FOUND)

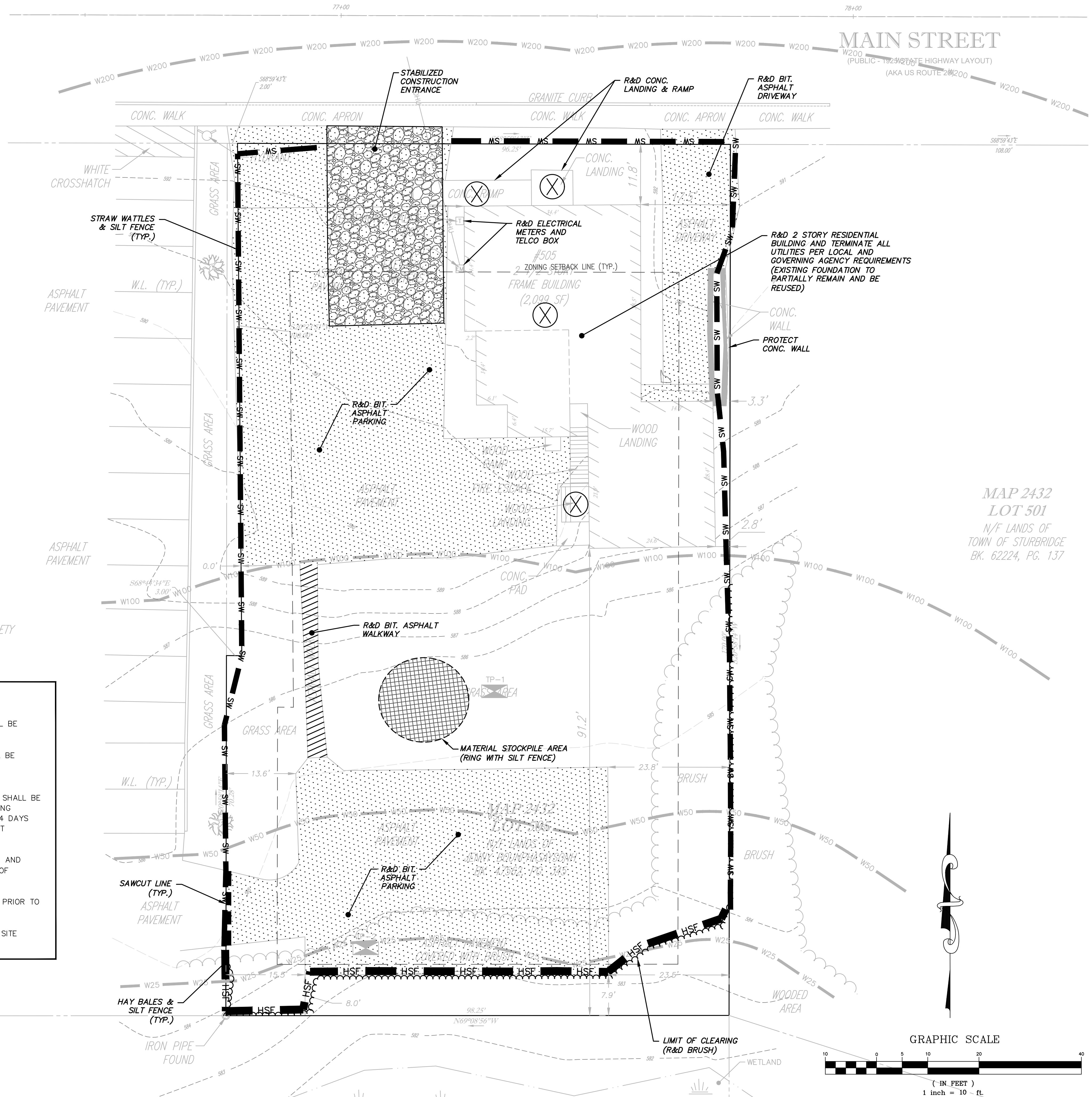

MAP 2432
LOT 507
N/F LANDS OF
TOWN OF STURBRIDGE
BK. 62224, PG. 137

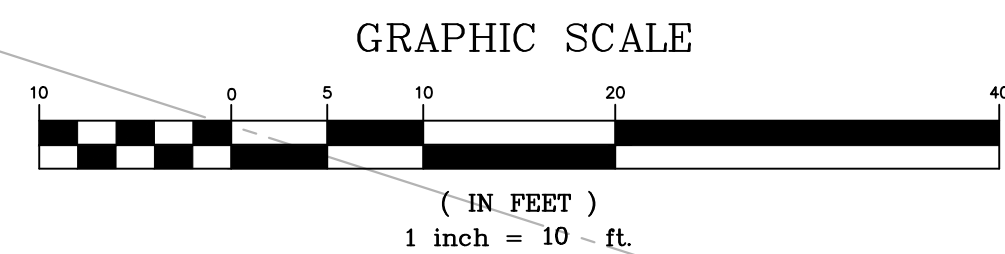

NO.	DATE	BY	DESCRIPTION
2	11/03/23	MRA	ISSUED FOR PERMITTING
1	12/22/22	MRA	ISSUED FOR PERMITTING



SITE DEMO & SEDIMENT AND EROSION CONTROL PLAN
MULTI-FAMILY RESIDENTIAL PROJECT
505 MAIN STREET, STURBRIDGE, MA 01518

STL GROUP LLC
P.O. BOX 688, STURBRIDGE, MA 01566

PREPARED FOR:
DATE: 12/22/22 SCALE: 1"=10'
DES. BY: ROM DRW. BY: ROM CHK. BY: MRA PRJ. NO.: 22152

C101

PROJECT ZONING INFORMATION

CRITERIA	REQUIRED	EXISTING	PROPOSED
ZONING DISTRICT	COMMERCIAL TOURIST	COMMERCIAL TOURIST	COMMERCIAL TOURIST
MINIMUM LOT AREA	10,000 SQ. FT.	16,466 SQ. FT.	16,466 SQ. FT.
FRONTAGE	100 FT.	96.25 FT.	96.25 FT.
FRONT SETBACK	25 FT.	11.7 FT.	11.7 FT.
SIDE SETBACK	10 FT.	2.8 FT.	3.0 FT.
REAR SETBACK	10 FT.	91.2 FT.	90.5 FT.
MAX. LOT COVERAGE	30%	12.7%	16%
MAX. # BUILDING STORIES	3	2	2
IMPERVIOUS AREA COVERAGE	N/A	59.6%	64.5%

ZONING DISTRICT SOURCE: THE ABOVE INFORMATION WAS OBTAINED FROM THE TOWN OF STURBRIDGE ZONING BYLAWS, AS AMENDED THROUGH JUNE 7, 2021.

PARKING SCHEDULE

REQUIRED PARKING
DWELLING UNIT: 2 SPACES/UNIT

8 UNITS TOTAL

TOTAL SPACES REQUIRED = 8 UNITS X 2 SPACES = 16 SPACES

PROPOSED PARKING

16 SPACES (INCLUDES 9 COMPACT SPACES (9' X 16'), AND 7 STANDARD SPACES (9' X 18'))

SNOW STORAGE NOTES

SNOW SHALL BE STORED WITHIN AREAS AS SHOWN ON THIS SHEET DESIGNATED BY THIS HATCHING

SNOW STORAGE LOCATIONS SHOWN REPRESENT THE MINIMUM NECESSARY AND THE OWNER SHALL EXPAND SUCH AREAS AS NEEDED. SNOW SHALL NOT BE PLACED SO AS TO INHIBIT VEHICLE SIGHT LINES FOR ENTERING AND EXITING THE SITE AND INTERNAL SITE CIRCULATION NOR PLACED TO INHIBIT SITE DRAINAGE.

SHEET NOTES

- ALL DIMENSIONS SHOWN ARE MEASURED FROM TOE OF CURB OR CENTER OF PAINTED LINE.
- CONTRACTOR SHALL RESTORE ALL DISTURBED AREAS WITH 6 INCHES OF LOAM AND SEED OR AS OTHERWISE NOTED ON THE PLANS.
- THE CONTRACTOR SHALL COORDINATE WITH PLANS BY OTHERS (ARCHITECTURAL, STRUCTURAL, MEP, ETC.)
- PAVEMENT MARKINGS SHALL BE PAINTED WITH WHITE TRAFFIC PAINT CONFORMING TO SECTION M7.01.08 OF THE MASSDOT STANDARD SPECIFICATIONS FOR HIGHWAYS AND BRIDGES, LATEST EDITION. LINE WIDTH SHALL BE 4 INCHES.
- PROPOSED LIGHTING SHALL BE BUILDING WALL PACK FIXTURE AS NECESSARY FOR BUILDING AND SITE SECURITY. ALL NEW FIXTURES SHALL BE LED, FULLY SHIELDED TO PREVENT LIGHT SPILLAGE ABOVE THE HORIZONTAL AND ONTO ADJUTING PROPERTIES, AND NIGHT SKY COMPLIANT.

PLANTING LIST

CODE	QTY.	BOTANICAL NAME	COMMON NAME	SIZE	NOTES
ORNAMENTAL TREES					
MPF	2	MALUS 'DONALD WYMAN'	'DONALD WYMAN' CRABAPPLE	4'-5' HT.	PLANT WHERE SHOWN
RM	1	ACER RUBRUM	RED MAPLE	4'-5' HT.	PLANT WHERE SHOWN

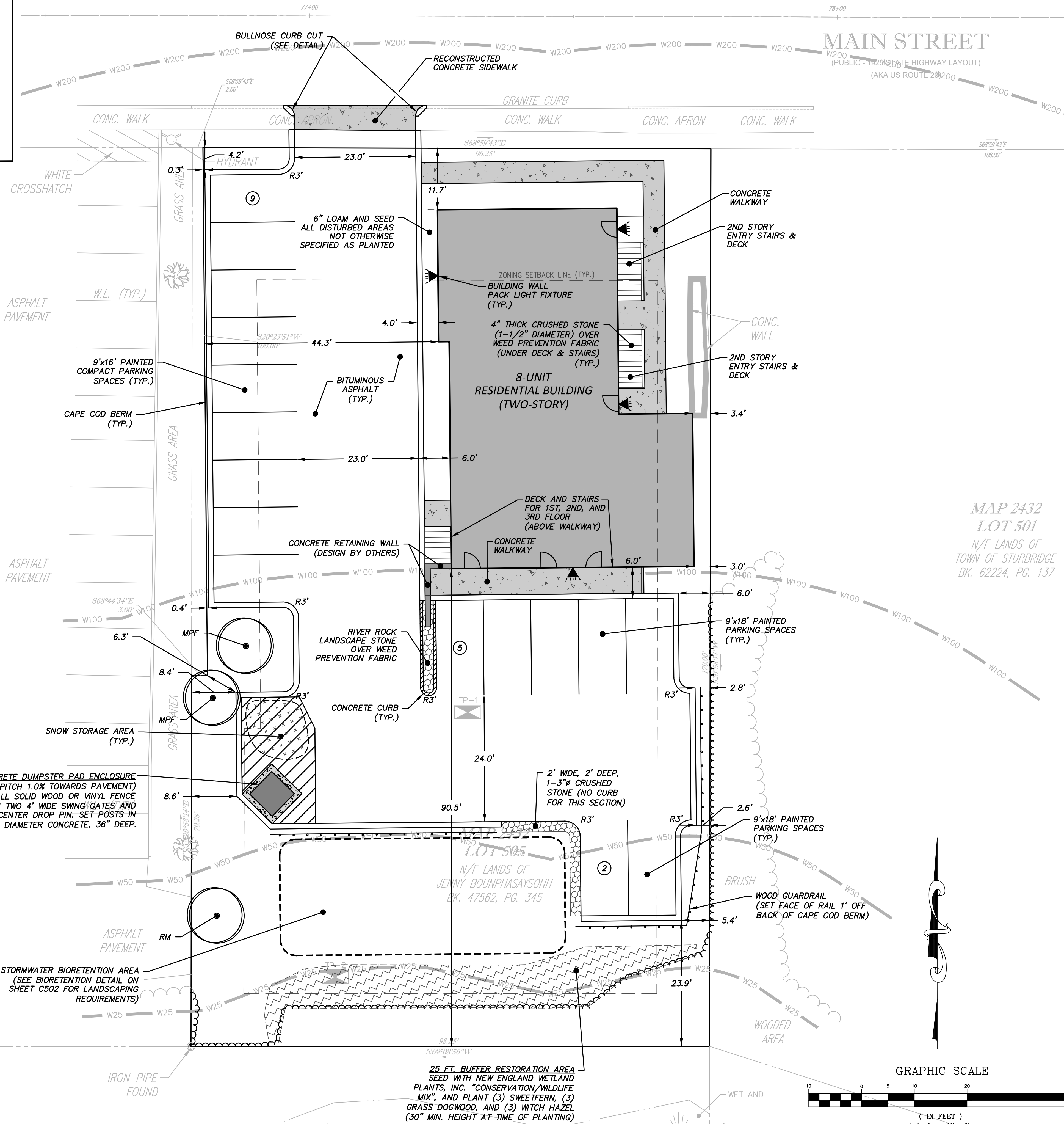

MAP 2432
LOT 507
N/F LANDS OF
ADVANT & BAPTISTE SOCIETY
(DEED NOT FOUND)

MAP 2432
LOT 501
N/F LANDS OF
TOWN OF STURBRIDGE
BK. 62224, PG. 137



LAYOUT PLAN
MULTI-FAMILY RESIDENTIAL PROJECT
505 MAIN STREET, STURBRIDGE, MA 01518

PREPARED FOR: STL GROUP, LLC
P.O. BOX 688, STURBRIDGE, MA 01566
DATE: 12/22/22
SCALE: 1"=10'
DES. BY: ROM
DRW. BY: ROM
CHK. BY: MRA
PRJ. NO.: 22152

NO.	DATE	BY	DESCRIPTION
2	11/03/23	MRA	ISSUED FOR PERMITTING
1	12/22/22	MRA	ISSUED FOR PERMITTING

GRAVES
ENGINEERING, Inc.
100 GROVE STREET | WORCESTER MA 01605
T 508-856-0321 | F 508-856-0357
gravesengineering.com

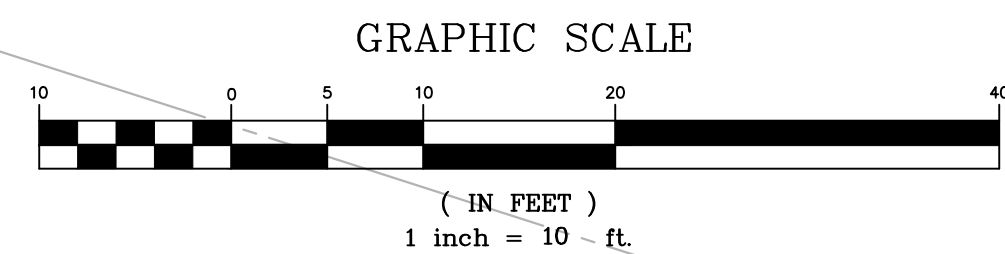

SOIL TESTING DATA

TP-1

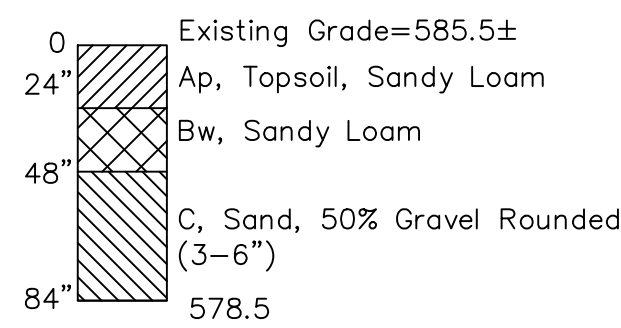

TP-2

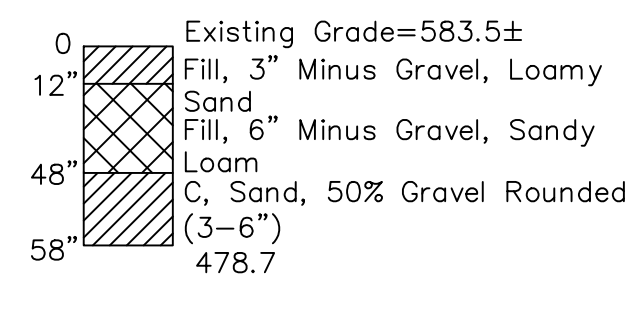

Weeping @ 65" (580.1)
ESHGWT @ 48" (581.5)

Weeping @ 48" (579.5)
ESHGWT @ 48" (579.5)

NOTES:

- SOIL TESTING TEST PITS WERE CONDUCTED BY MICHAEL ANDRADE, P.E., MASSDEP SOIL EVALUATOR #SE2681, OF GRAVES ENGINEERING ON 12/08/22. TESTS PITS EXCAVATED BY CIESLA CONSTRUCTION WITH A TAKEUCHI TB135 MINI TRACK. TESTS PITS WERE PERFORMED FOR STORMWATER MANAGEMENT DESIGN PURPOSES ONLY.
- ESHGWT= ESTIMATED SEASONAL HIGH GROUNDWATER TABLE

SHEET NOTES

- PROVIDE POSITIVE DRAINAGE IN ALL FINISH GRADED WORK AREAS INCLUDING AWAY FROM ALL BUILDINGS.
- ADJUST ALL STRUCTURES (MANHOLES, WATER GATE VALVES, SHUTOFFS, ETC.) TO PROPOSED FINISH GRADES WITHIN THE LIMIT OF WORK.
- ALL DISTURBED AREAS OUTSIDE OF PAVEMENT SHALL BE RESTORED WITH 6 INCHES OF LOAM AND SEEDED OR LANDSCAPED IN ACCORDANCE WITH THE LANDSCAPING PLANS.
- ALL FINISHED GRASSED SLOPES EQUAL TO OR GREATER THAN A 3:1 SLOPE SHALL BE STABILIZED WITH AN EROSION CONTROL MATTING SUCH AS SC-150 BY NORTH AMERICAN GREEN, CURLEX II BY AMERICAN EXCELSIOR, OR ENGINEER APPROVED EQUAL. COORDINATE MATTING LOCATIONS WITH THE LANDSCAPE PLANS AND GROUND COVER MATERIALS.
- PROPOSED GRADES AS SHOWN SHALL BE CARRIED TO ALL PAVEMENT CORNERS HOWEVER GRADE ADJUSTMENTS SHALL BE MADE BY THE CONTRACTOR AS NECESSARY TO PROVIDE POSITIVE DRAINAGE FROM ALL CORNERS.
- SPOT GRADE KEY:
(E) = EXISTING GRADE TO BE MAINTAINED CB = CATCH BASIN
TC = TOP OF CURB FINISH GRADE HP = HIGH POINT
BC = BOTTOM OF CURB FINISH GRADE LP = LOW POINT
FFE = BUILDING FINISH FLOOR ELEVATION ME = MATCH EXISTING
VIF = VERIFY IN FIELD (CONTRACTOR)
TW = TOP OF WALL (FINISH GRADE)
BW = BOTTOM OF WALL (FINISH GRADE)
- SITE SOILS PER USDA-NRCS WEB SOIL SURVEY ARE POOTATUCK FINE SANDY LOAM (MAP UNIT 2A), AND CANTON FINE SANDY LOAM (MAP UNIT 420B). ON-SITE SOIL TESTING WAS CONDUCTED ON DECEMBER 8, 2022. SEE LOG THIS SHEET.
- ALL NEW PAVEMENT AND CONCRETE SURFACES SHALL BE CONSTRUCTED TO PROPOSED GRADES AS SHOWN AND SHALL BE SMOOTH AND UNIFORM ELIMINATING DEFORMITIES, DEPRESSIONS, PUDDLES, AND TRIP HAZARDS. PROVIDE POSITIVE DRAINAGE ON ON ALL NEW PAVEMENT AND CONCRETE SURFACES, AWAY FROM BUILDINGS, AND TO EXISTING CATCH BASINS, OUTFALLS OR OTHER COLLECTION POINTS.
- UNLESS NOTED OTHERWISE, PROPOSED WALKWAYS SHALL HAVE RUNNING (LONGITUDINAL) SLOPES NO GREATER THAN 4.5%. CROSS SLOPES OF WALKWAYS SHALL BE PITCHED TO DRAIN BUT NO MORE THAN 1.5%. NEW WALKWAYS SHALL MATCH (BE FLUSH WITH) EXISTING ELEVATIONS WHERE SHOWN OR NOTED WITH CHANGES IN LEVELS (ELEVATIONS) NO GREATER THAN 1/4-INCH, AND WITH FINISH GRADES OF EXISTING AND PROPOSED BIT. WALKS, CONCRETE PADS, ETC.
- UTILITY MATERIALS, CONSTRUCTION, AND TESTING SHALL COMPLY WITH TOWN OF STURBRIDGE STANDARDS.

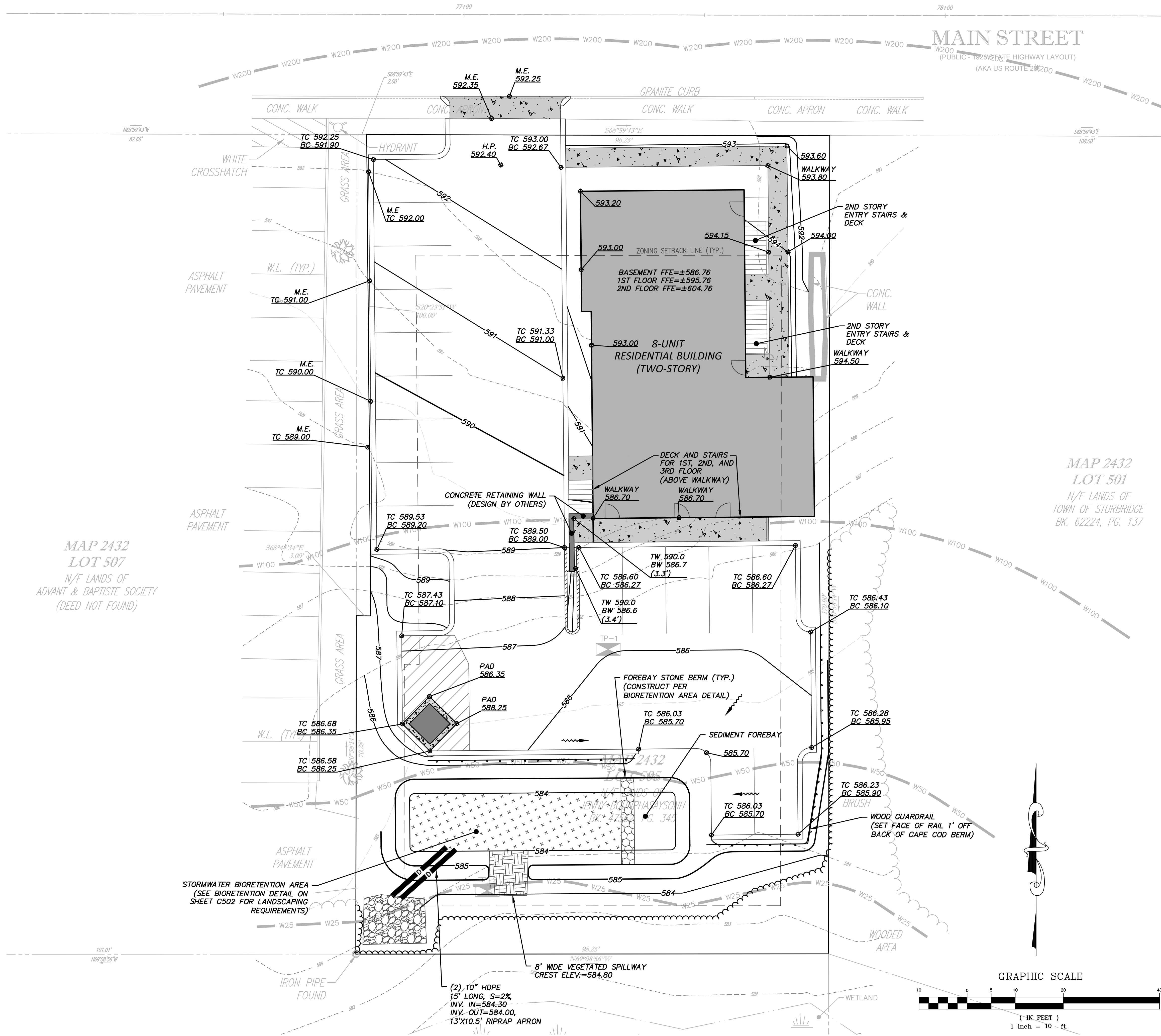

MAP 2432
LOT 507
N/F LANDS OF
ADVANT & BAPTISTE SOCIETY
(DEED NOT FOUND)

MAP 2432
LOT 501
N/F LANDS OF
TOWN OF STURBRIDGE
BK. 62224, PG. 137

GRAVES ENGINEERING, Inc.
100 GROVE STREET | WORCESTER MA 01605
T 508-856-0321 | F 508-856-0377
gravesengineering.com

NO.	DATE	BY	DESCRIPTION
2	11/03/23	MRA	ISSUED FOR PERMITTING
1	12/22/22	MRA	ISSUED FOR PERMITTING

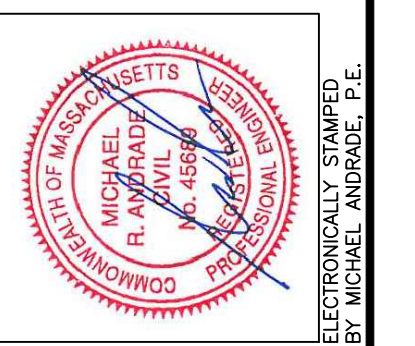

GRADING & DRAINAGE PLAN
MULTI-FAMILY RESIDENTIAL PROJECT
505 MAIN STREET, STURBRIDGE, MA 01518

STL GROUP LLC
P.O. BOX 688, STURBRIDGE, MA 01566

DATE: 12/22/22 SCALE: 1"=10'
DES. BY: ROM DRW. BY: ROM CHK. BY: MRA PRJ. NO.: 22152

C103

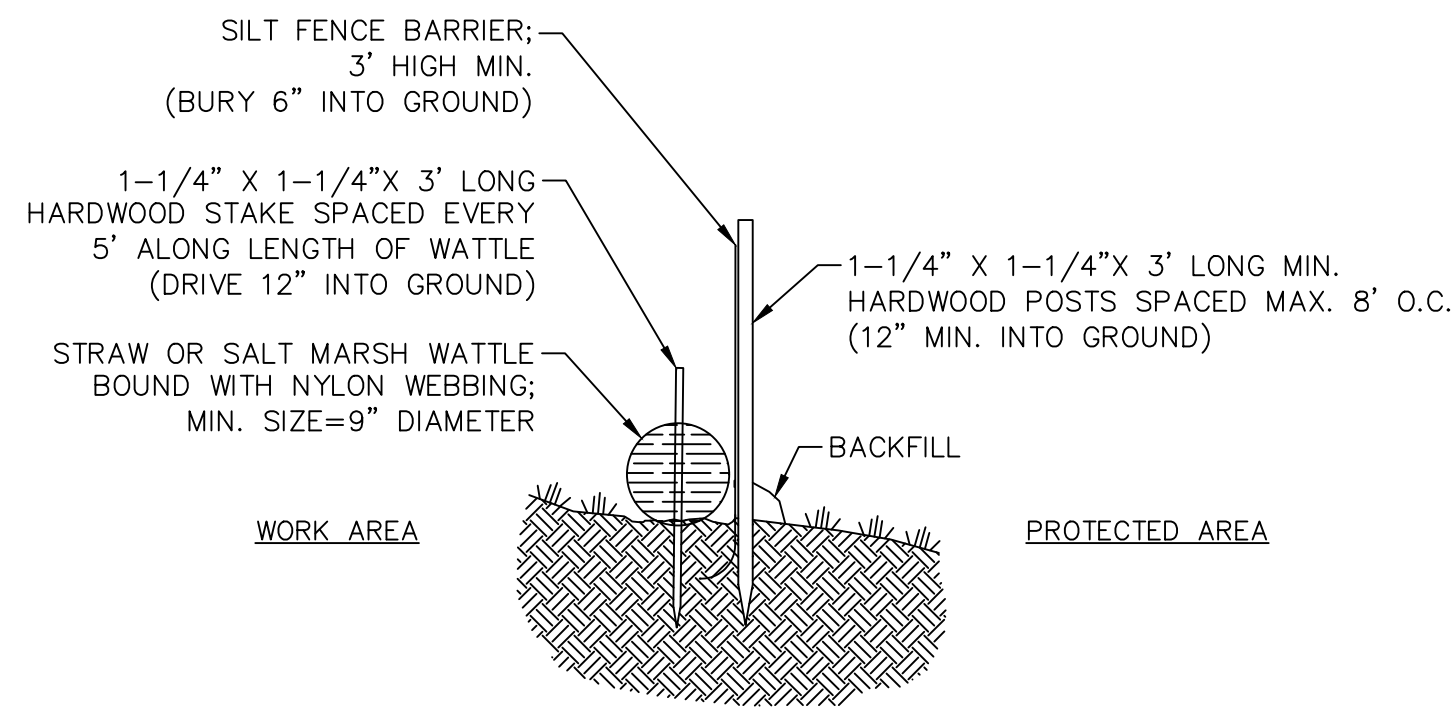

STRAW WATTLE & SILT FENCE NTS

NOTE:

- 1) PROVIDE A 3' TO 6' LEVEL AREA BETWEEN THE WATTLE AND THE TOE OF ANY SLOPE TO PROVIDE AREA FOR SEDIMENT ACCUMULATION.

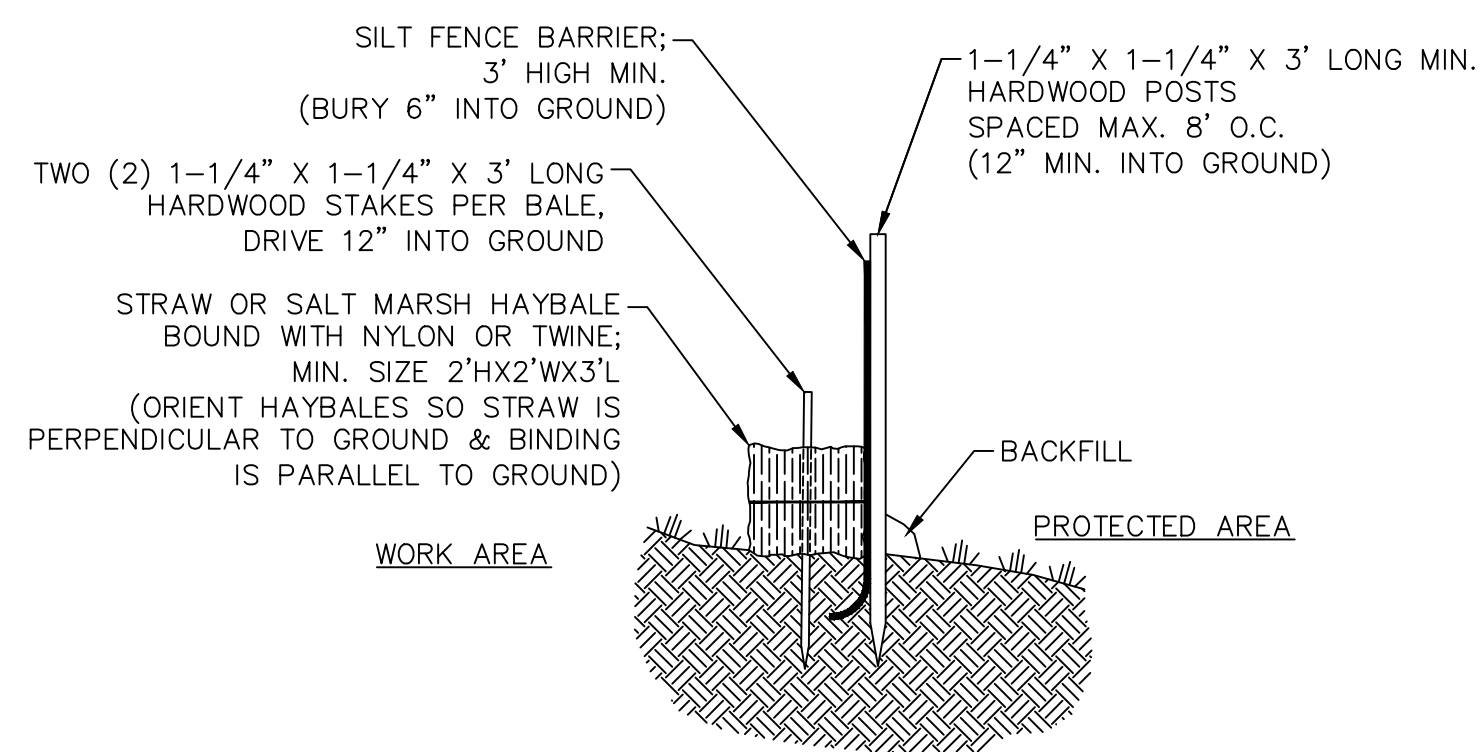

HAYBALE & SILT FENCE NTS

NOTE:

- 1) PROVIDE A 3' TO 6' LEVEL AREA BETWEEN THE HAYBALE AND THE TOE OF ANY SLOPE TO PROVIDE AREA FOR SEDIMENT ACCUMULATION.

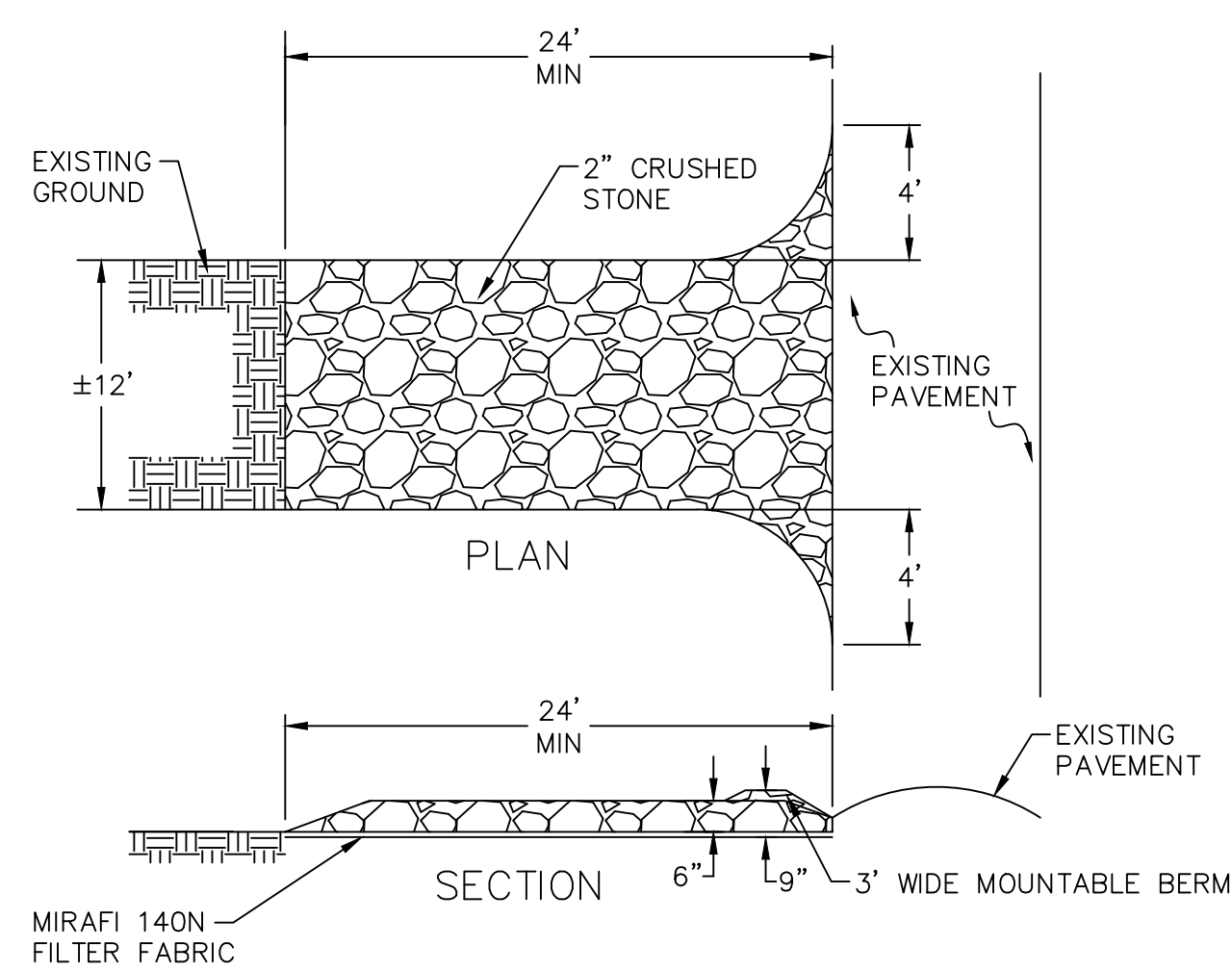

STABILIZED CONSTRUCTION ENTRANCE NTS

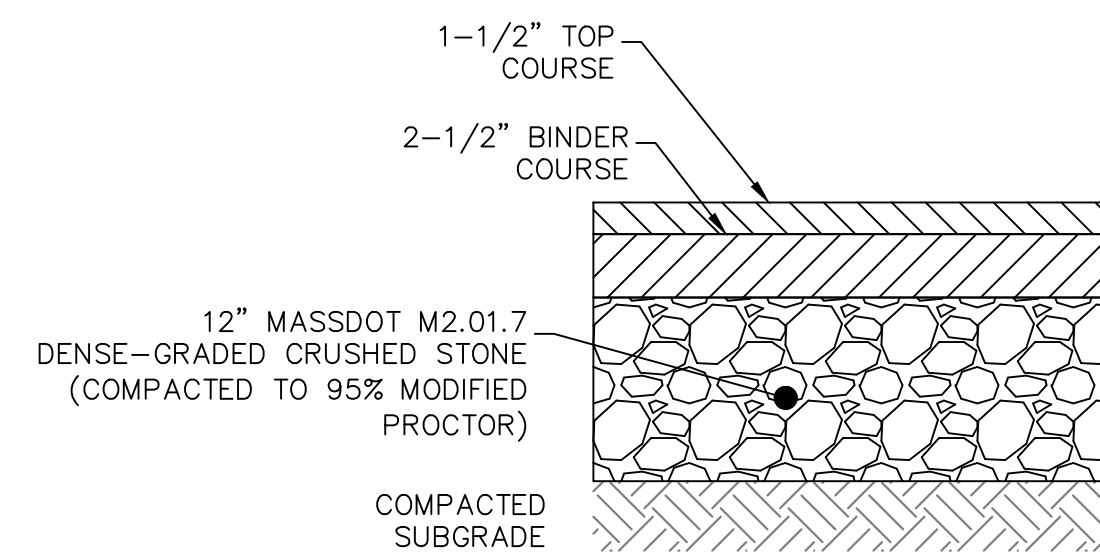

PAVEMENT SECTION NTS

NOTES:

- 1) TAMP ALL ASPHALT EDGES THAT ABUT LAWN, LANDSCAPED OR OTHER SOFT SURFACE.
- 2) BINDER COURSE: - MASSDOT M3.11.03, TABLE A, "HMA INTERMEDIATE COURSE DENSE BINDER" OR SUPERPAVE INTERMEDIATE COURSE - 19.0MM (MIXTURE DESIGNATION SIC - 19.0).
- 3) TOP COURSE: - MASSDOT M3.11.03, TABLE A, "SURFACE COURSE STANDARD TOP" OR SUPERPAVE SURFACE COURSE - 12.5MM (MIXTURE DESIGNATION SSC - 12.5).

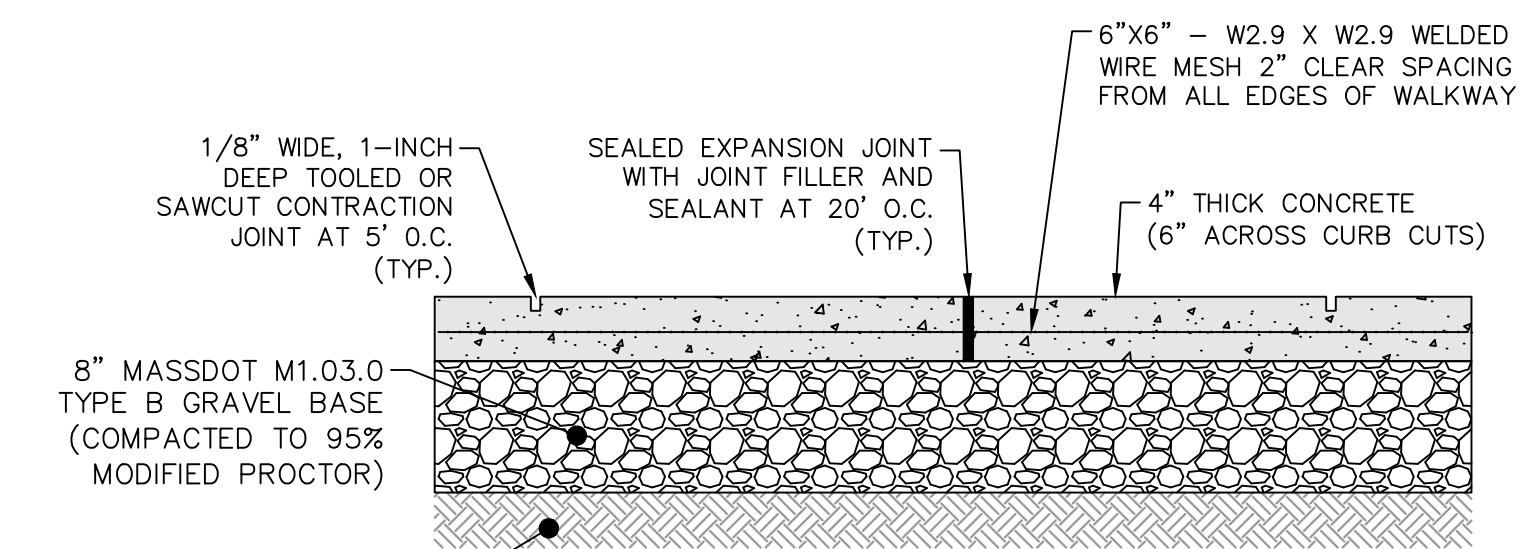

CONCRETE WALKWAY NTS

NOTES:

- 1) CONCRETE MIX DESIGN SHALL BE FOR EXTERIOR USE; AIR-ENTRAINED, 4,000 PSI MIN. (28-DAY), 3/4" AGGREGATE.
- 2) WHEN THE WALKWAY ABUTS A STRUCTURE OR EXISTING HARD SURFACE (CONCRETE, ETC.), INSTALL AN EXPANSION JOINT ACROSS THE ENTIRETY OF THE ABUTTING FACE WITH PREFORMED FIBER JOINT FILLER AND FILL WITH 1" DEEP OF POLYURETHANE JOINT SEALANT.
- 3) WALKWAYS SHALL HAVE A LIGHT BROOM FINISH PERPENDICULAR TO THE DIRECTION OF FOOT TRAFFIC. THERE SHALL BE NO SMOOTHED TOOL JOINTS; BROOM FINISH SHALL EXTEND TO THE EDGES OF THE PAD AND ACROSS ANY JOINTS.

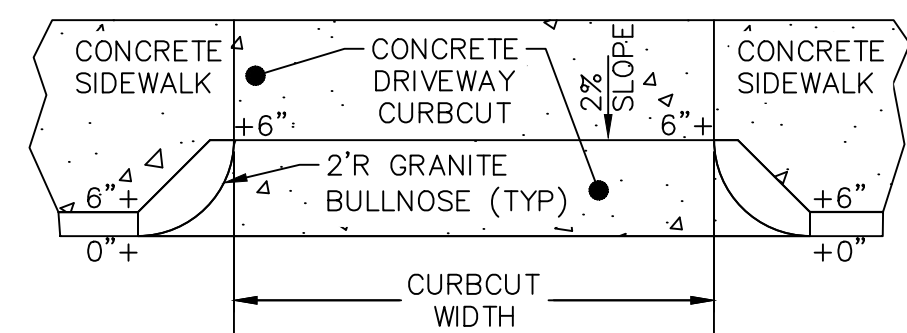

BULLNOSE CURB CUT NTS

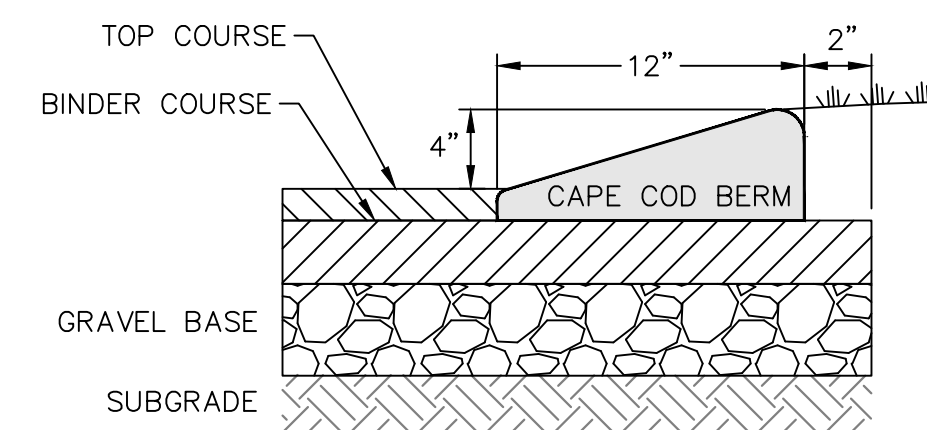

CAPE COD BERM NTS

NOTE:

- 1) BERM SHALL BE LAID ON BINDER COURSE AND KEYED INTO TOP COURSE.

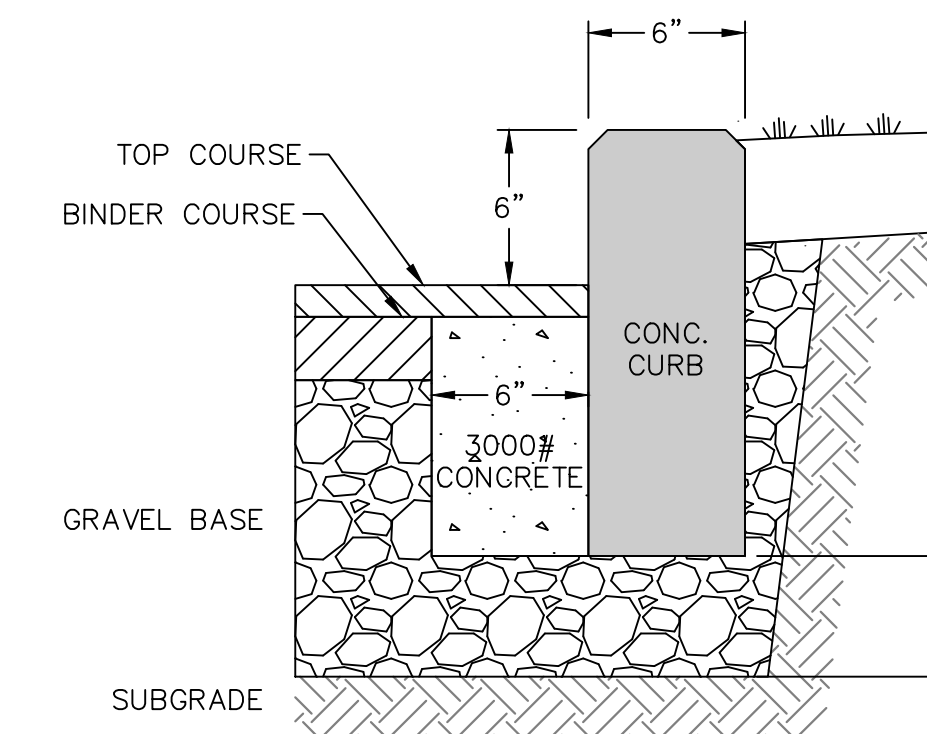

PRECAST CONCRETE CURB NTS

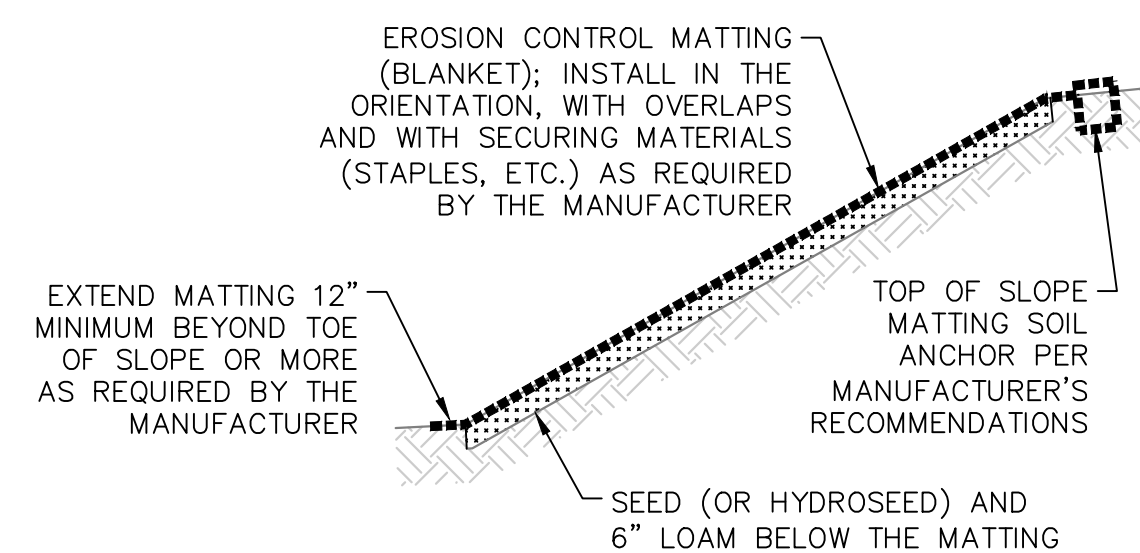

EROSION CONTROL BLANKET SLOPE STABILIZATION NTS

NOTES:

- 1) EROSION CONTROL MATTING (BLANKETS) SHALL BE INSTALLED ON ALL FINISHED SLOPES SHOWN EQUAL TO OR EXCEEDING A 3:1 SLOPE (33.5%).
- 2) INSTALLATION SHALL STRICTLY FOLLOW THE MANUFACTURER'S RECOMMENDATIONS AND INSTRUCTIONS.
- 3) UNLESS OTHERWISE SPECIFIED ON THE DRAWINGS FOR A PARTICULAR LOCATION AND APPLICATION, ACCEPTABLE EROSION CONTROL BLANKETS FOR GENERAL SLOPE STABILIZATION ARE: SC150 BY NORTH AMERICAN GREEN, CURLEX II BY AMERICAN EXCELSIOR COMPANY, OR LANDLOK C2 BY PROPEX (OR ENGINEER APPROVED EQUAL).

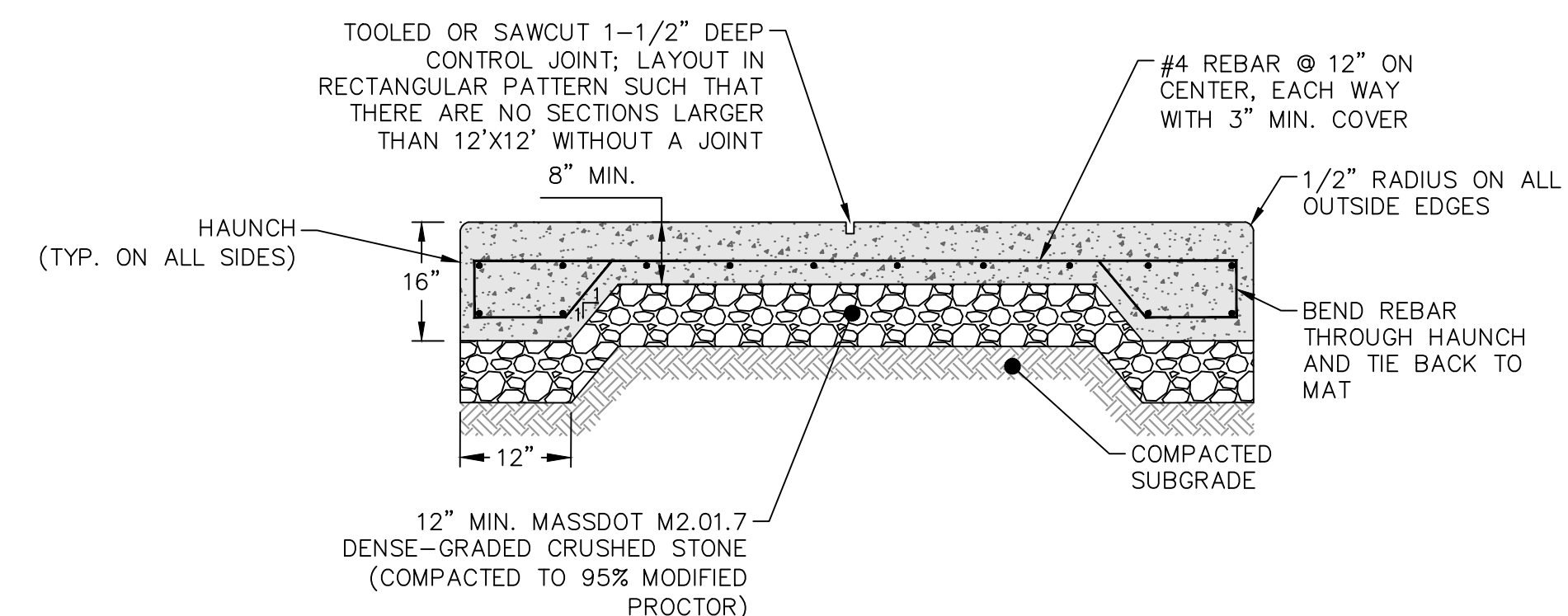

CONCRETE PAD-HEAVY DUTY NTS

NOTES:

- 1) THIS DETAIL APPLIES TO THE PROPOSED DUMPSTER PAD.
- 2) CONCRETE MIX DESIGN SHALL BE FOR EXTERIOR USE; AIR-ENTRAINED, 4,000 PSI MIN. (28-DAY), 3/4" AGGREGATE.
- 3) OMIT THE HAUNCH WHEN ABUTTING ANOTHER HARD SURFACE SUCH AS EXISTING CONCRETE (BITUMINOUS IS NOT A HARD SURFACE).
- 4) WHEN THE PAD ABUTS A STRUCTURE OR EXISTING HARD SURFACE (CONCRETE, ETC.), INSTALL AN EXPANSION JOINT ACROSS THE ENTIRETY OF THE ABUTTING FACE WITH PREFORMED FIBER JOINT FILLER AND FILL WITH 1" DEEP OF POLYURETHANE JOINT SEALANT.
- 5) PAD SHALL HAVE A MEDIUM BROOM FINISH. THERE SHALL BE NO SMOOTHED TOOL JOINTS; BROOM FINISH SHALL EXTEND TO THE EDGES OF THE PAD AND ACROSS ANY JOINTS.

NO.	DATE	BY	DESCRIPTION
2	11/03/23	MRA	ISSUED FOR PERMITTING
1	12/22/22	MRA	ISSUED FOR PERMITTING

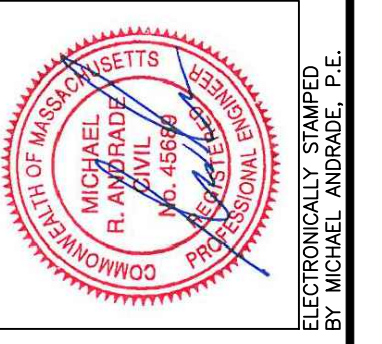

PREPARED FOR:	STL GROUP, LLC
DATE:	12/22/22
SCALE:	1"=10'
DES. BY:	ROM
DRW. BY:	ROM
CHK. BY:	MRA
PRJ. NO.:	22152

SITE DETAILS - 1
MULTI-FAMILY RESIDENTIAL PROJECT
505 MAIN STREET, STURBRIDGE, MA 01518

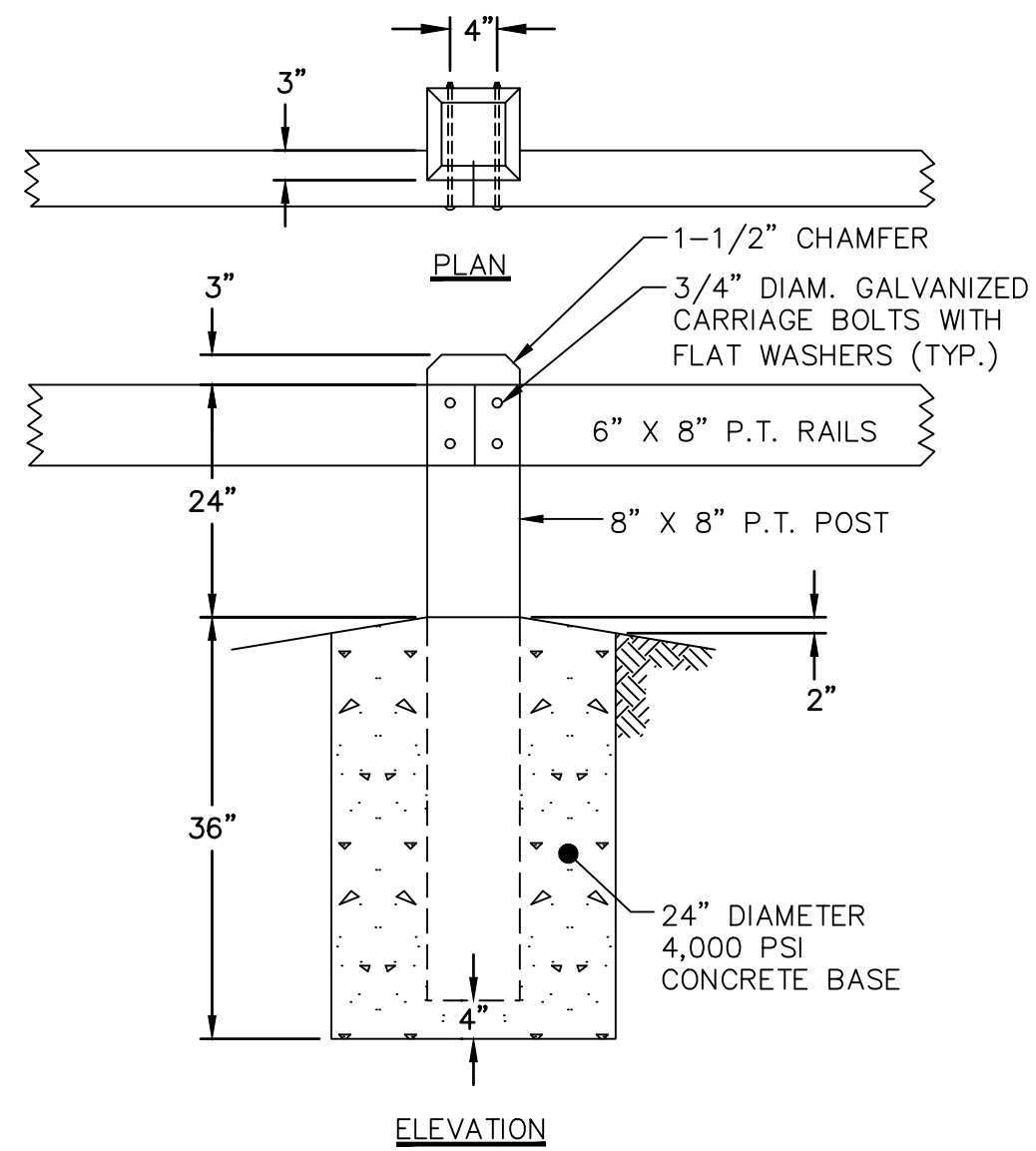

WOOD GUARDRAIL NTS

NOTE:

- 1) POST SPACING SHALL BE 8'-0" ON CENTER.

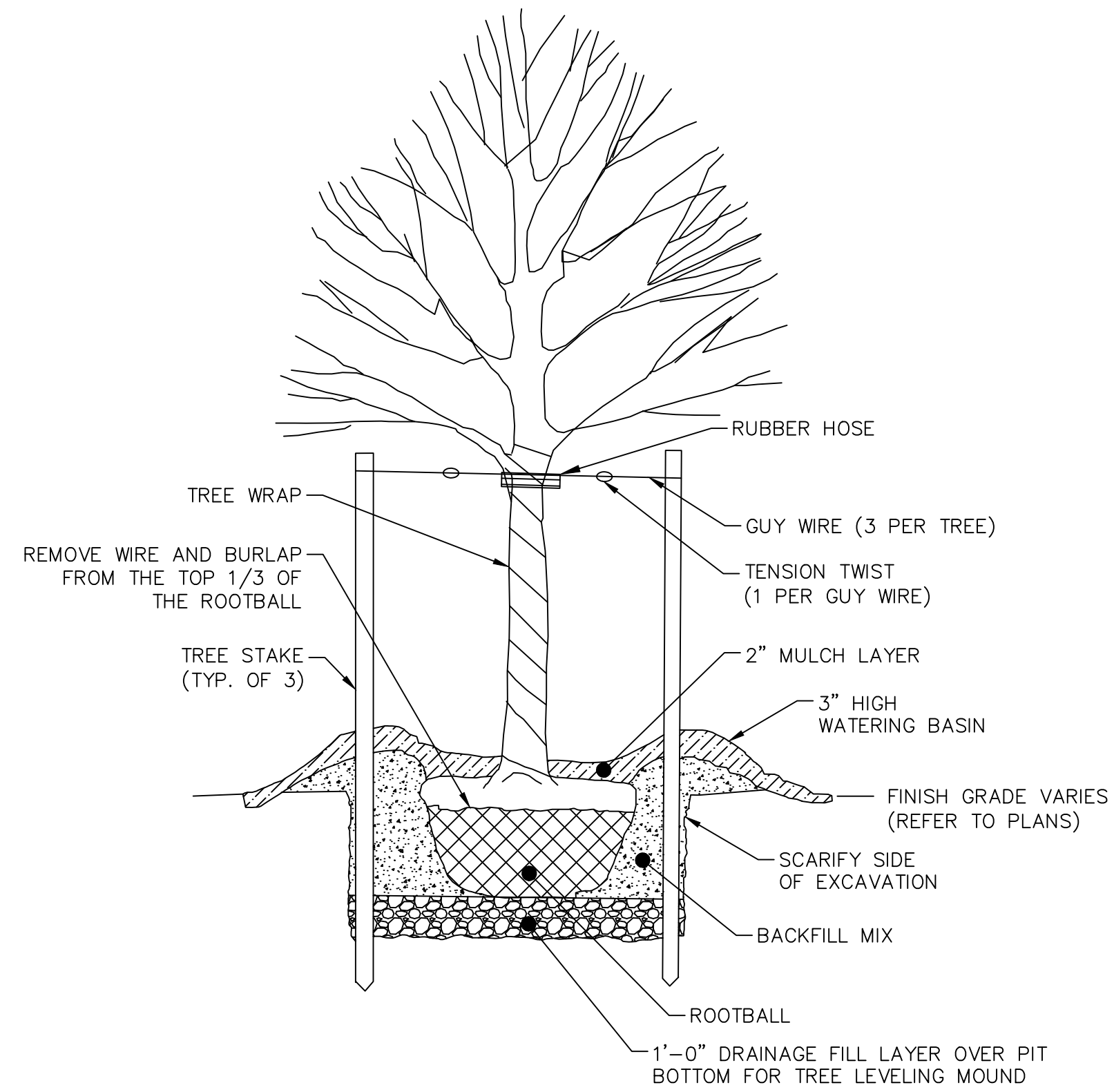

TREE PLANTING NTS

NOTES:

- 1) SET TREE ROOT CROWN 2" ABOVE FINISH GRADE.
- 2) DO NOT PLACE SOIL OVER ROOTBALL.
- 3) A 6-FOOT DIAMETER BARK MULCH BED WITH A DEPTH OF 3 INCHES SHALL BE PLACED AROUND THE TRUNK OF EACH PROPOSED TREE.
- 4) ALL PLANTINGS SHALL BE WATERED AND FERTILIZED AS NECESSARY UNTIL ESTABLISHED. THE CONTRACTOR SHALL INSTALL A SLOW-RELEASE WATERING BAG AT EACH TREE PLANTING AND MAINTAIN THE BAG FILLED WITH WATER UNTIL FINAL COMPLETION.
- 5) TREES SHALL BE SUPPORTED BY TEMPORARY STAKING AS NECESSARY UNTIL ESTABLISHED.

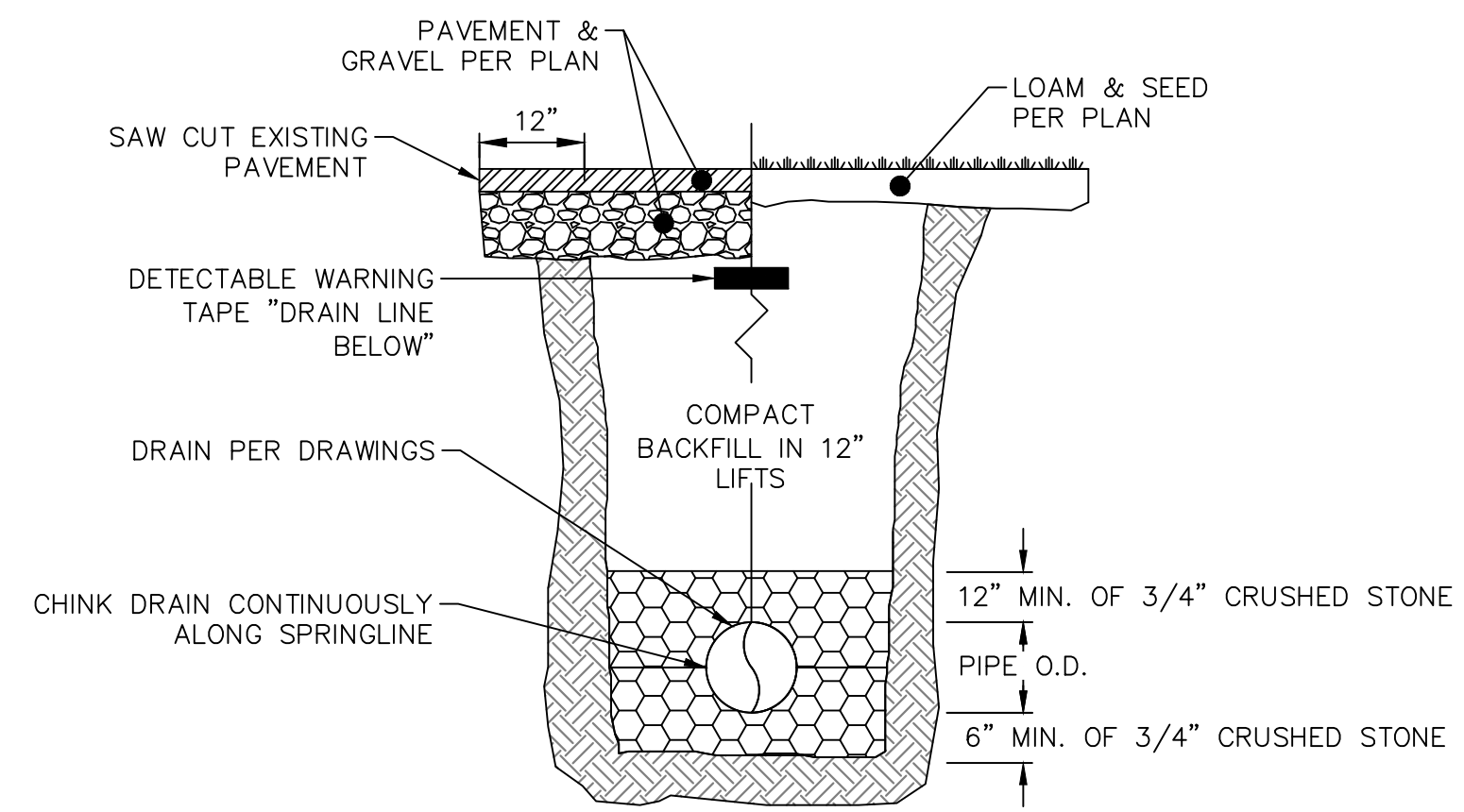

HDPE/PVC DRAIN TRENCH SECTION NTS

NOTES:

- 1) BACKFILL SHALL BE AN AASHTO CLASS III SOIL; EITHER TRENCH SPOILS OR AN IMPORTED SAND AND GRAVEL WITH FINES AND COMPACTED TO 90% OF THE PROCTOR DENSITY.
- 2) BACKFILL OF HDPE PIPE SHALL CONFORM TO ASTM D2321 AND/OR MANUFACTURER'S SPECIFICATIONS.

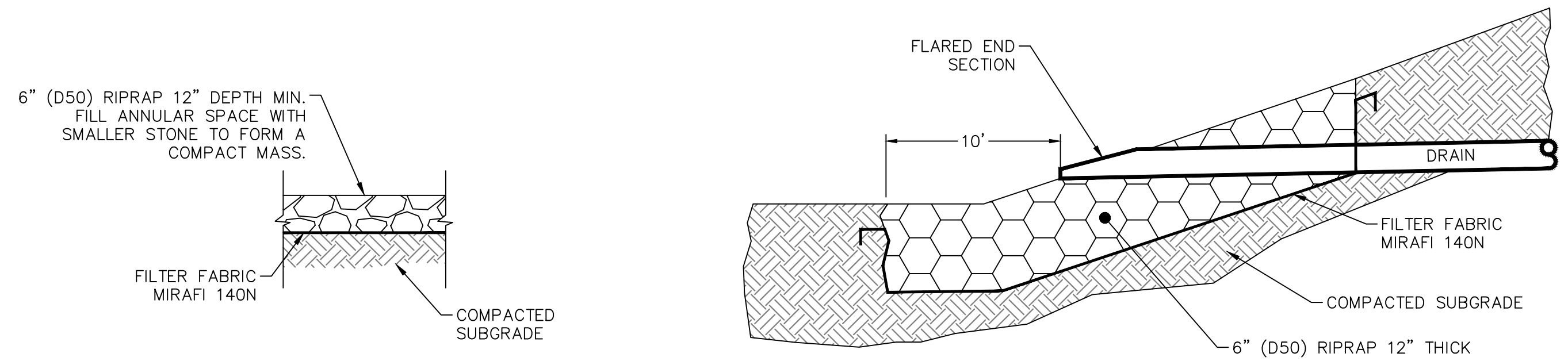

RIPRAP APRON SECTION NTS

NOTE:

- 1) THIS DETAIL APPLIES TO ALL SPECIFIED RIPRAP APPLICATIONS.

RIPRAP OUTLET DETAIL NTS

STORMWATER BIORETENTION AREA NOTES

1. PLANTINGS WITHIN THE BIORETENTION AREA MAY BE SUBSTITUTED WITH MORE READILY AVAILABLE SPECIES APPROVED BY GRAVES ENGINEERING, INC. ALL PLANT SPECIES MUST BE NATIVE TO MASSACHUSETTS AND A NON-INVASIVE SPECIES. PLANTINGS SHALL BE ARRANGED IN A NATURAL MANNER; ENGINEER SHALL APPROVE A PLANTING PLAN PREPARED BY THE CONTRACTOR PRIOR TO PLANTING.
2. BIORETENTION SOIL MIX SHALL BE A MIX OF SAND, COMPOST AND SOIL AS FOLLOWS: 40% SAND, 20-30% TOPSOIL, AND 30-40% COMPOST.
3. SOIL MIX MUST BE UNIFORM, FREE OF STONES, STUMPS, ROOTS OR OTHER SIMILAR OBJECTS LARGER THAN 2 INCHES; CLAY CONTENT LESS THAN 5%, pH BETWEEN 5.5 AND 6.5.
4. SOIL MIX SAND COMPONENT SHALL BE GRAVELLY SAND MEETING ASTM D422 AS FOLLOWS:

SIEVE SIZE	% PASSING
2"	100
3/4"	70-100
1/4"	50-80
#40	15-40
#200	0-3
5. SOIL MIX TOPSOIL COMPONENT SHALL BE SANDY LOAM, LOAMY SAND OR LOAM TEXTURE. COMPOST COMPONENT SHALL BE PROCESSED YARD WASTE IN COMPLIANCE WITH MASSDEP GUIDELINES AND NOT CONTAIN BIOSOLIDS.
6. THE CONTRACTOR SHALL BE RESPONSIBLE FOR SUBMITTING SOIL TESTING TO VERIFY THE SOIL USED FALLS WITHIN THESE LIMITS.
7. SPILLWAY TURF REINFORCEMENT MATTING (TRM) SHALL BE NORTH AMERICAN GREEN MODEL P300, OR ENGINEER APPROVED EQUAL.
8. INTERIOR SIDE SLOPES SHALL BE SEEDED WITH NEW ENGLAND WETLAND PLANTS "EROSION CONTROL/RESTORATION MIX FOR DETENTION BASINS AND MOIST SITES" OR AN ENGINEER APPROVED EQUAL.
9. THE TERM "BIORETENTION AREA" IS SYNONYMOUS WITH THE TERM "RAIN GARDEN".

STORMWATER BIORETENTION AREA PLANTING LIST

CODE	QTY.	BOTANICAL NAME	COMMON NAME	SIZE	NOTES
GRASSES					
PV	3	PANICUM VIRGATUM	SWITCH GRASS	2 GAL.	18" O.C.
PA	3	PENNSETUM ALOPECUROIDES	FOUNTAIN GRASS	2 GAL.	18" O.C.
PERENNIALS					
ATU	15	ASCLEPIAS TUBEROSA	BUTTERFLY MILKWEED	2 GAL.	24" O.C.
ER	15	ECHINOPS RITRO	GLOBE THISTLE	1 GAL.	18" O.C.
ATR	15	ANAPHALIS TRIPLINERVIS	PEARLY EVERLASTING	1 GAL.	18" O.C.
SHRUBS					
IV	3	ITEA VIRGINICA	VIRGINIA SWEETSPICE	36" SPREAD	B&B
VD	3	VIBURNUM DENTATUM	ARROWWOOD	3 GAL.	B&B
AI	3	ALNUS INCANA	SPECKLED ADLER	#2 CONT.	CONT.

BIORETENTION AREA & FOREBAY ELEVATION SCHEDULE

	FOREBAY	BIORETENTION AREA
TOP OF BERM ELEV.	585.00	585.50
BOTTOM ELEV.	584.00	584.00
100 YR PEAK ELEV.	-	584.88
SPILLWAY ELEV.	-	584.80
BOTTOM OF SOIL MIX	-	581.85

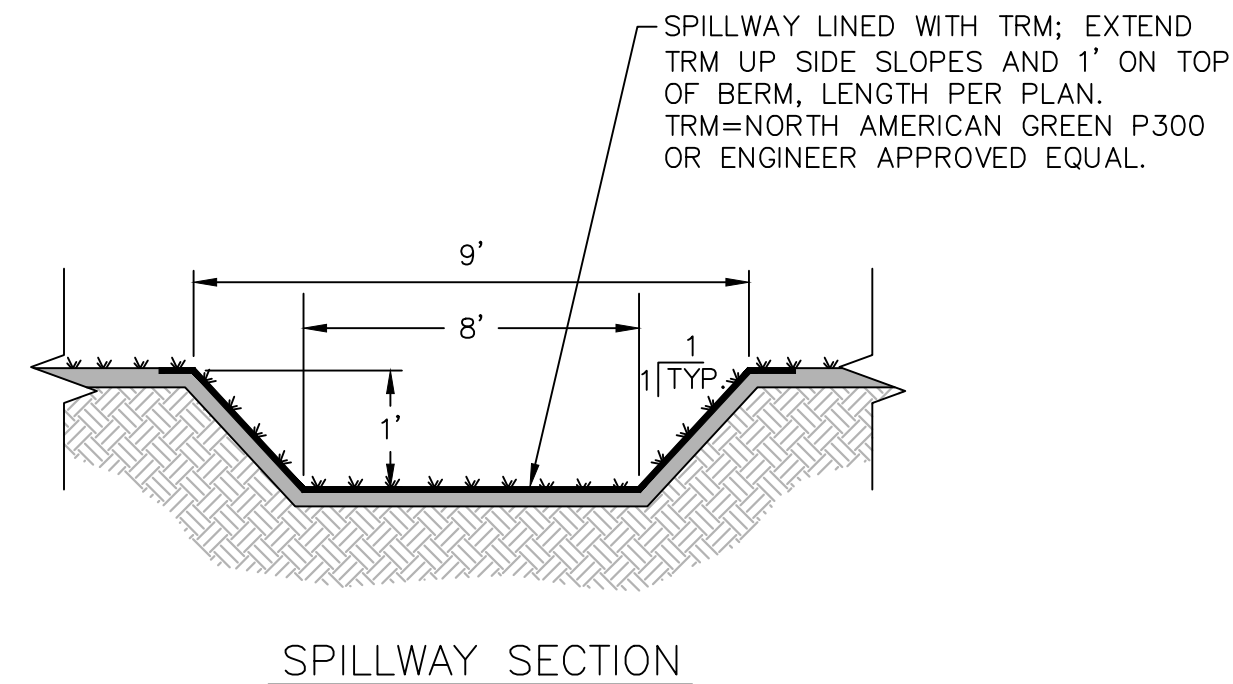

SPILLWAY SECTION

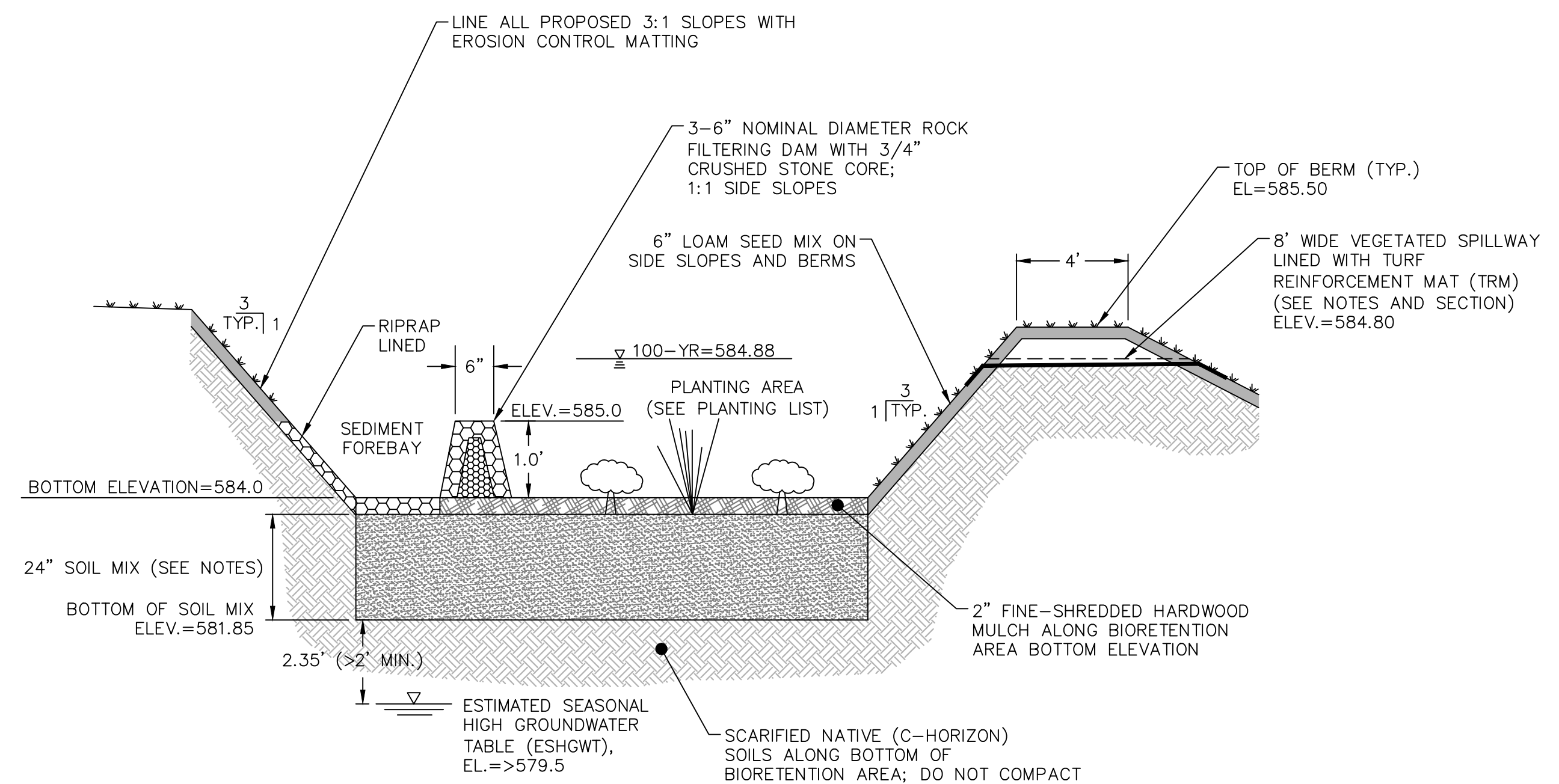

STORMWATER BIORETENTION AREA

NO.	DATE	BY	DESCRIPTION
2	11/03/23	MRA	ISSUED FOR PERMITTING
1	12/22/22	MRA	ISSUED FOR PERMITTING

