

GROUND-MOUNTED PHOTOVOLTAIC SYSTEM

200 ROUTE 15
STURBRIDGE, MASSACHUSETTS

AUGUST 1, 2023

REVISED: NOVEMBER 15, 2023

ZONING COMPLIANCE TABLE		
CRITERIA: ARTICLE XIV – INTENSITY REGULATIONS (§300-14.2, SPECIAL USE)		
	REQUIRED	PROPOSED
MINIMUM LOT AREA	1 ACRE	13.92 ACRES
MINIMUM LOT FRONTAGE	200'	1,619.5'±
MINIMUM STREET SETBACK	50'	54.2'
MINIMUM SIDE/REAR YARD SETBACK	30'	192.3'
MAX. LOT COVERAGE (%)	30%	17.0%
MAXIMUM HEIGHT	35'	N/A
CRITERIA: ARTICLE X – SOLAR ENERGY FACILITIES (§300-10.1 – §300.10.12)		
	REQUIRED	PROPOSED
MINIMUM FRONT/SIDE/REAR YARD SETBACK	100'	100.6'
MINIMUM RESIDENTIAL LANDSCAPED BUFFER	200'	200.0'

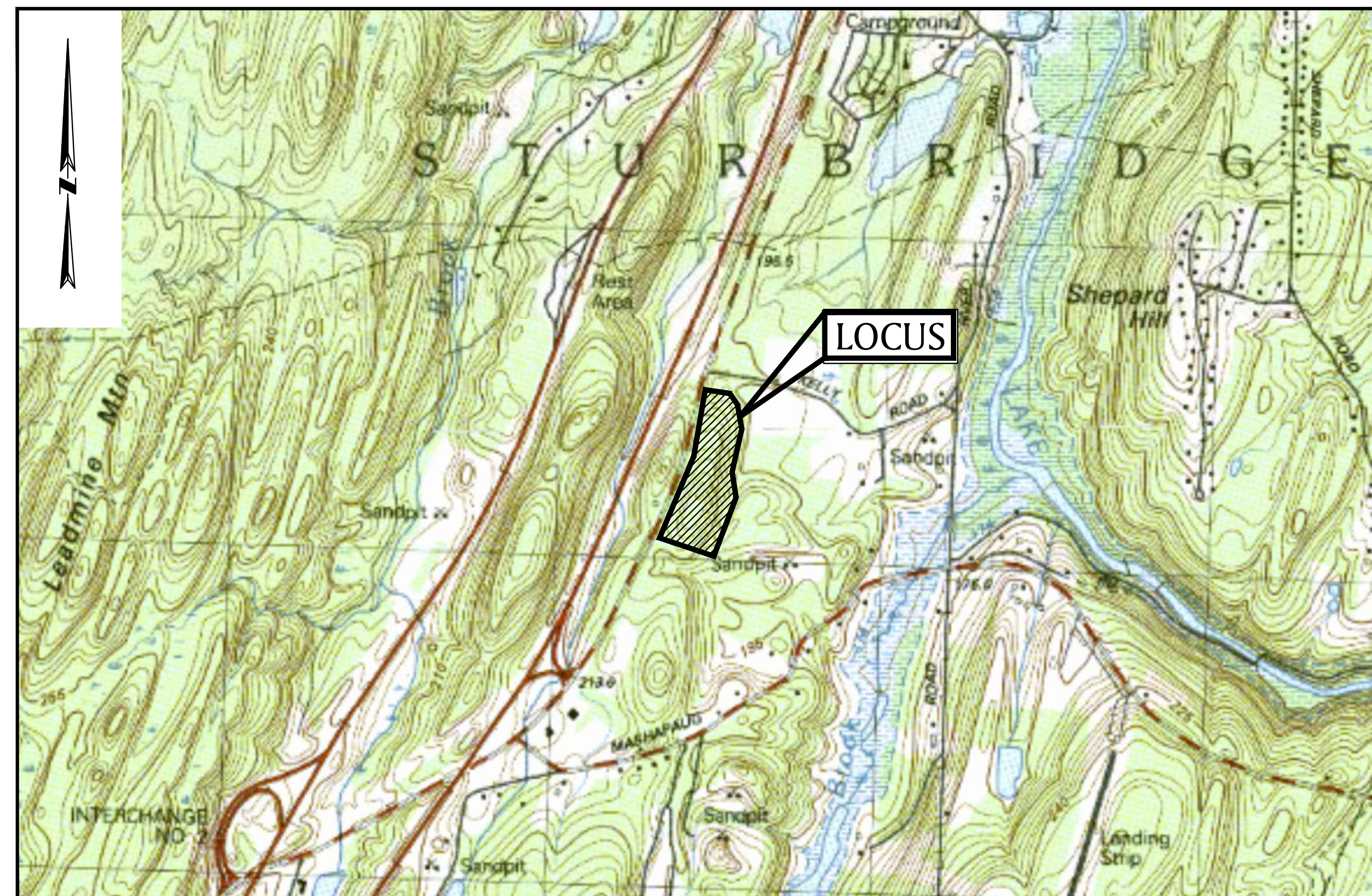

LOCUS MAP

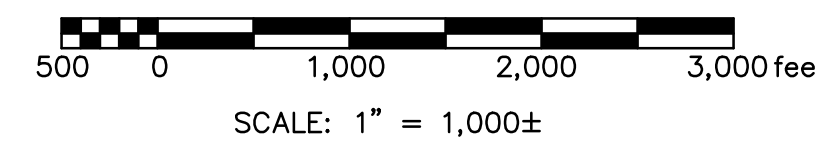

11/15/23

PREPARED FOR:

STURBRIDGE PV, LLC
2420 17TH STREET
DENVER, CO 80202

PREPARED BY:

BSC GROUP
349 Main Street - Route 28
W. Yarmouth, Massachusetts
02673
508 778 8919

ISSUED FOR PERMITTING
NOT FOR CONSTRUCTION

INDEX OF DRAWINGS

- 1 TITLE SHEET
- 2 EXISTING CONDITIONS PLAN
- 3 EROSION & SEDIMENTATION CONTROL PLAN
- 4 LAYOUT & MATERIALS PLAN
- 5 GRADING PLAN
- 6 DRAINAGE PLAN
- 7 PLANTING PLAN
- 8-9 DETAIL SHEETS

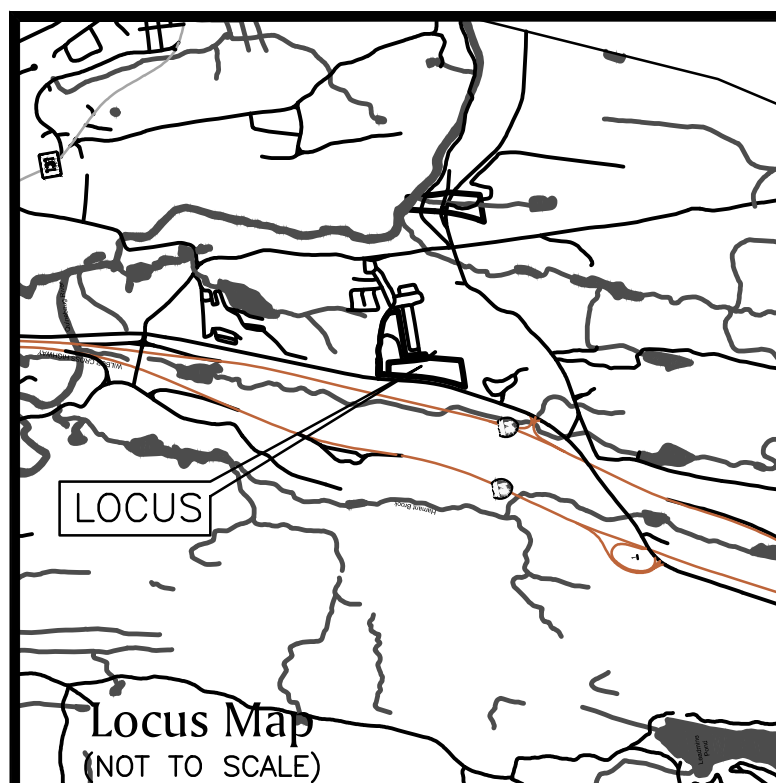

***UTILITY NOTE**

EXISTING UTILITIES, WHERE SHOWN HEREON, ARE APPROXIMATE. THE CONTRACTOR SHALL BE RESPONSIBLE FOR PROPERLY LOCATING AND COORDINATING ANY ON-SITE ACTIVITY WITH DIG-SAFE AND THE APPROPRIATE UTILITY COMPANY AND MAINTAINING EXISTING UTILITY SYSTEM SERVICE. DIG-SAFE SHALL BE NOTIFIED PER RHODE ISLAND GENERAL LAWS TITLE 39 CHAPTER 39-1,2, AT 1-888-344-7233. NO GUARANTEE IS IMPLIED OR INTENDED AS TO THE ACCURACY, LOCATION OR THAT ALL UTILITIES AND/OR SUBSURFACE STRUCTURES ARE SHOWN. THE CONTRACTOR SHALL VERIFY SIZE, LOCATION AND INVERTS OR UTILITIES AND STRUCTURES AS REQUIRED PRIOR TO THE START OF CONSTRUCTION.

LEGEND

- BIT BITUMINOUS
- CATCH BASIN
- CHAIN LINK FENCE
- CONC CONCRETE
- DECIDUOUS TREE
- DWP DETECTABLE WARNING PAD
- DRAIN MANHOLE
- DRILL HOLE
- ELECTRIC MANHOLE
- HYDRANT
- IRON ROD FENCE
- IRON ROD
- LIGHT POLE
- MANHOLE
- PEDESTRIAN SIGNAL
- S SEWER MANHOLE
- SIGN
- SWL SINGLE WHITE LINE
- TELEPHONE MANHOLE
- TOP CURB/BOTTOM CURB
- TOP WALL/BOTTOM WALL
- TRAFFIC MASTARM
- UTILITY POLE W/LIGHT & TRANSFORMER
- VERTICAL GRANITE CURB
- WATER GATE
- OVERHEAD WIRES
- ONE FOOT CONTOUR
- FIVE FOOT CONTOUR
- UNDERGROUND DRAIN
- UNDERGROUND ELECTRIC
- UNDERGROUND GAS
- UNDERGROUND SEWER
- UNDERGROUND TELEPHONE
- UNDERGROUND WATER

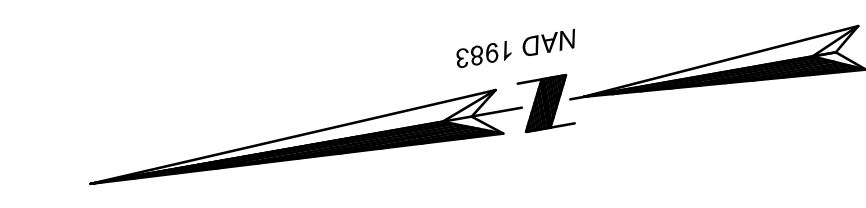

OWNER:
30 SWIFT, LLC
SEE PLAN FOR ABUTTING PARCEL OWNER INFORMATION

GENERAL NOTES:

- 1) THE EXISTING CONDITIONS SHOWN HEREON DEPICT THE SUBJECT SITE AS IT APPEARED DURING A FIELD SURVEY CONDUCTED BY BSC GROUP, INC. BETWEEN OCTOBER 11, 2022 AND NOVEMBER 18, 2022.
- 2) THE ABOVE MENTIONED FIELD SURVEY IS BASED ON NAD 1983 HORIZONTAL AND NAVD 1988 VERTICAL DATUM (TEMPORARY BENCH MARKS (TBM) SET) AS DERIVED FROM GPS OBSERVATIONS MADE AT THE TIME OF THE SURVEY.
- 3) THE UTILITIES SHOWN ON THIS PLAN ARE TAKEN FROM LOCATIONS OF SURFACE STRUCTURES AND ALSO RECORD INFORMATION SUPPLIED BY UTILITY COMPANIES AND PB 90 PG 52-62.
- 4) WETLANDS FLAGS WF17-WF42 WERE FIELD LOCATED BY BSC GROUP AS PART OF AN ON-THE-GROUND SURVEY. WETLAND FLAGS GCA1-GCA16, GCA49-GCA59 AND GCB1-GCB11 ARE SHOWN FROM LATITUDE AND LONGITUDE VALUES PROVIDED BY GODDARD CONSULTING, LLC AND THE LATITUDE AND LONGITUDE VALUES PROVIDED WERE CONVERTED TO MASS STATE PLANE COORDINATE VALUES USING CORPSCON 6 SOFTWARE.

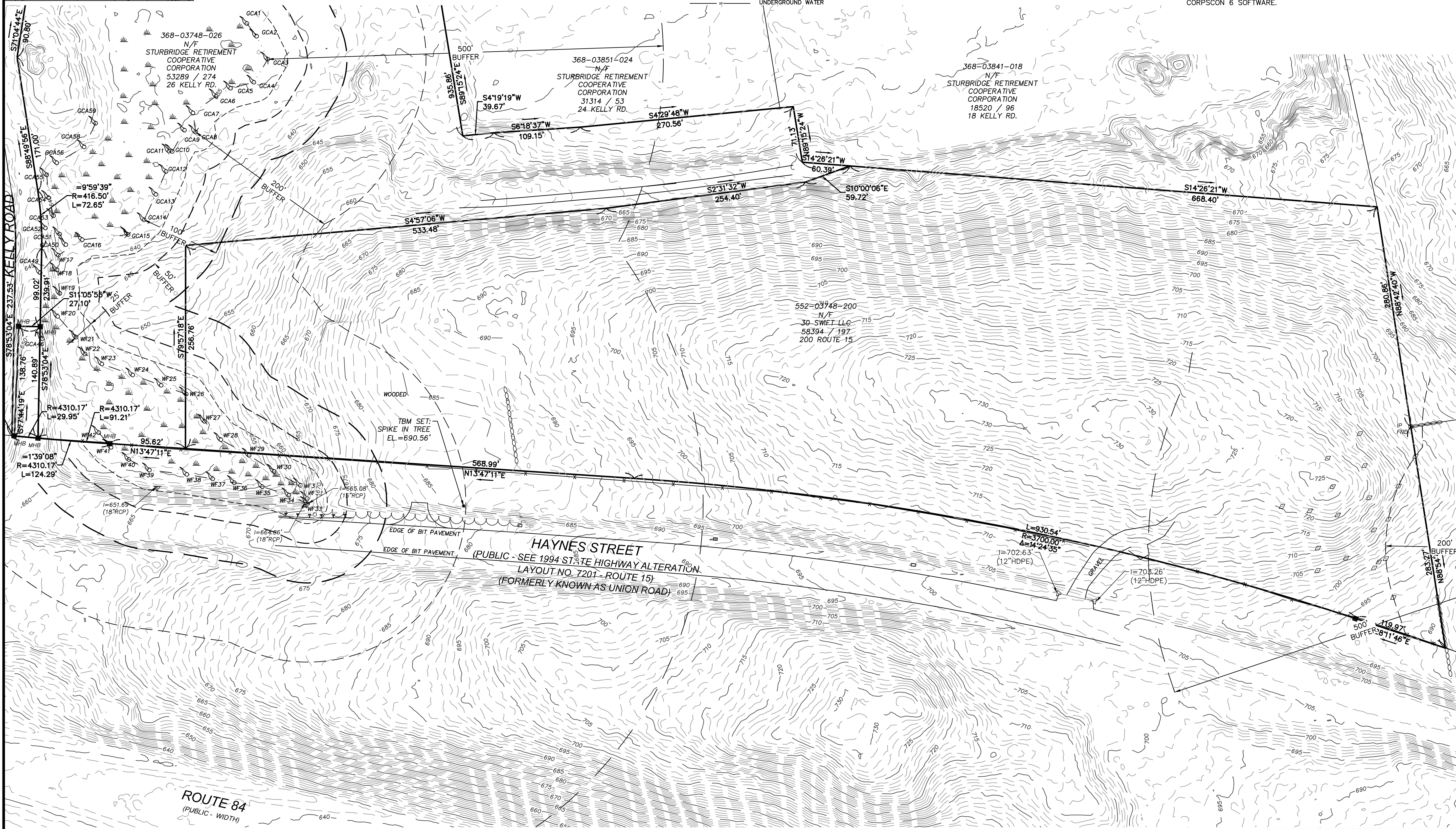

Christopher W. McNary 08/03/2023
CHRISTOPHER W. MCNARY #47396 DATE
PROFESSIONAL LAND SURVEYOR

GROUND-MOUNTED PHOTOVOLTAIC SYSTEM

200 ROUTE 15
IN
STURBRIDGE MASSACHUSETTS (WORCESTER COUNTY)

EXISTING CONDITIONS PLAN

APRIL 26, 2023

REVISIONS:

NO.	DATE	DESC.
1.	6/14/23	REV. WF FLAGS & BUFFERS

PREPARED FOR:
STURBRIDGE PV, LLC
2420 17TH STREET
DENVER, CO 80202

349 Main Street - Route 28
West Yarmouth, Massachusetts
02673
508 778 8919

© 2022 BSC Group, Inc.
SCALE: 1" = 60'
0 30 60 120 FEET

FILE: \5074500\5074500EC-2023.dwg
DWG: 5074500EC-2023
JOB. NO: 5-0745.00 SHEET 2 OF 9

**ISSUED FOR PERMITTING
NOT FOR CONSTRUCTION**

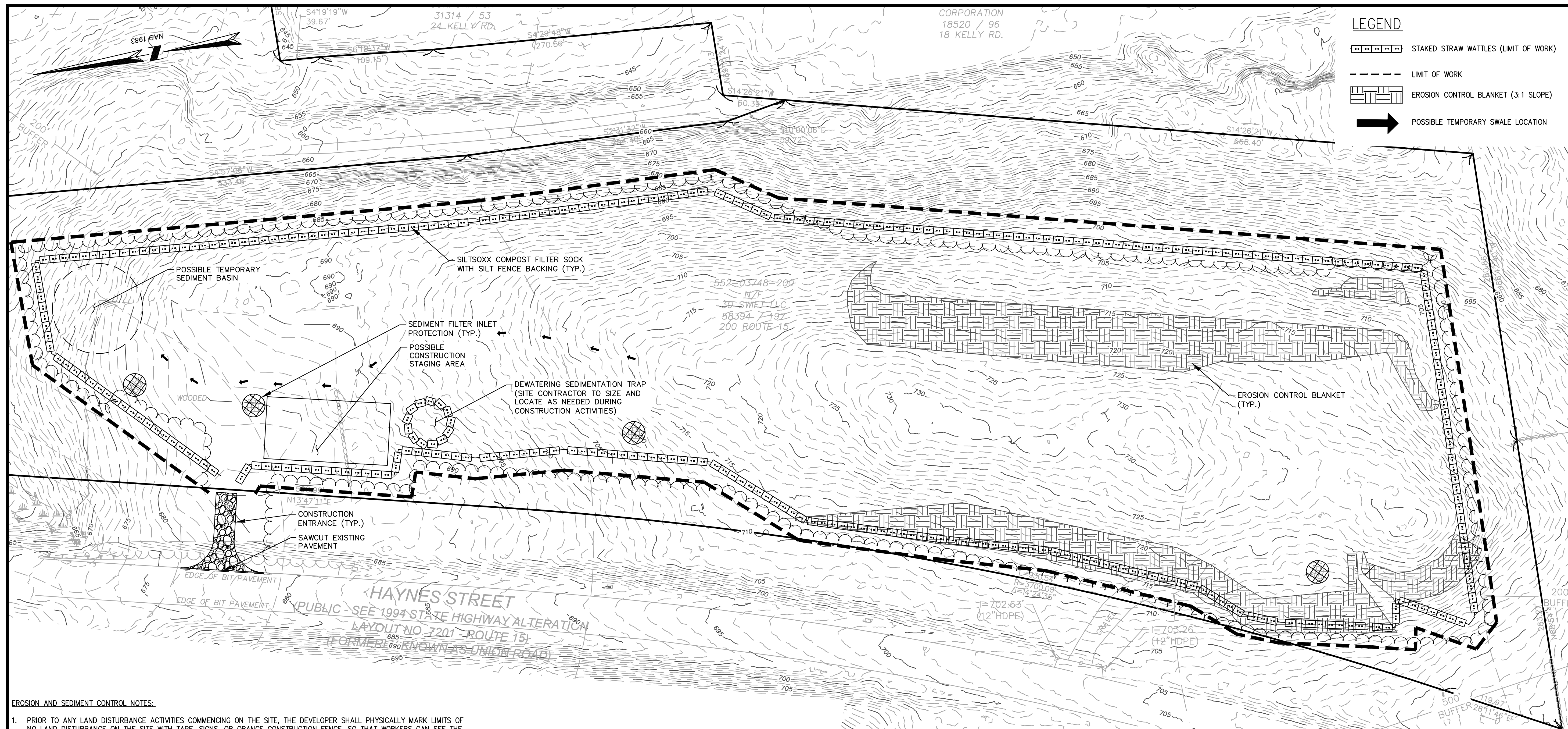

LEGEND

- STAKED STRAW WATTLES (LIMIT OF WORK)
- LIMIT OF WORK
- EROSION CONTROL BLANKET (3:1 SLOPE)
- POSSIBLE TEMPORARY SWALE LOCATION



11/15/23

BRIAN G. YERGATIAN
PROFESSIONAL ENGINEER

GROUND-MOUNTED PHOTOVOLTAIC SYSTEM
200 ROUTE 15
IN
STURBRIDGE MASSACHUSETTS (WORCESTER COUNTY)

EROSION & SEDIMENT CONTROL PLAN
AUGUST 1, 2023

EROSION AND SEDIMENT CONTROL NOTES:

1. PRIOR TO ANY LAND DISTURBANCE ACTIVITIES COMMENCING ON THE SITE, THE DEVELOPER SHALL PHYSICALLY MARK LIMITS OF NO LAND DISTURBANCE ON THE SITE WITH TAPE, SIGNS, OR ORANGE CONSTRUCTION FENCE, SO THAT WORKERS CAN SEE THE AREAS TO BE PROTECTED. THE PHYSICAL MARKERS SHALL REMAIN IN PLACE UNTIL A CERTIFICATE OF COMPLETION HAS BEEN ISSUED.
2. APPROPRIATE EROSION AND SEDIMENT CONTROL MEASURES SHALL BE INSTALLED PRIOR TO SOIL DISTURBANCE. MEASURES SHALL BE TAKEN TO CONTROL EROSION WITHIN THE PROJECT AREA. SEDIMENT IN RUNOFF WATER SHALL BE TRAPPED AND RETAINED WITHIN THE PROJECT AREA. WETLAND AREAS AND SURFACE WATERS SHALL BE PROTECTED FROM SEDIMENT.
3. MINIMIZE TOTAL AREA OF DISTURBANCE AND PROTECT NATURAL FEATURES AND SOIL.
4. THE CONTRACTOR SHALL SEQUENCE ALL ACTIVITIES TO MINIMIZE SIMULTANEOUS AREAS OF DISTURBANCE. MASS CLEARING AND GRADING OF THE ENTIRE SITE SHALL BE AVOIDED.
5. MINIMIZE SOIL EROSION AND CONTROL SEDIMENTATION DURING CONSTRUCTION.
6. DIVERT UNCONTAMINATED WATER AROUND DISTURBED AREAS.
7. INSTALL AND MAINTAIN ALL EROSION AND SEDIMENT CONTROL MEASURES IN ACCORDANCE WITH THE MANUFACTURER'S SPECIFICATIONS AND GOOD ENGINEERING PRACTICES OR IN ACCORDANCE WITH THE 2017 EPA CONSTRUCTION GENERAL PERMIT.
8. PROTECT AND MANAGE ON AND OFF-SITE MATERIAL STORAGE AREAS (OVERBURDEN AND STOCKPILES OF DIRT, BORROW AREAS, OR OTHER AREAS USED SOLELY BY THE PERMITTED PROJECT ARE CONSIDERED A PART OF THE PROJECT).
9. COMPLY WITH APPLICABLE FEDERAL, STATE AND LOCAL LAWS AND REGULATIONS INCLUDING WASTE DISPOSAL, SANITARY OR SEWER REGULATIONS, AND AIR QUALITY REQUIREMENTS, INCLUDING DUST CONTROL.
10. SEDIMENT SHALL BE REMOVED ONCE THE VOLUME REACHES 1/4 TO 1/2 THE HEIGHT OF THE EROSION CONTROL DEVICE. SEDIMENT SHALL BE REMOVED FROM SILT FENCE PRIOR TO REACHING THE LOAD-BEARING CAPACITY OF THE SILT FENCE WHICH MAY BE LOWER THAN 1/4 TO 1/2 THE HEIGHT.
11. SEDIMENT FROM SEDIMENT TRAPS OR SEDIMENTATION PONDS SHALL BE REMOVED WHEN DESIGN CAPACITY HAS BEEN REDUCED BY 50 PERCENT.
12. BMPs TO BE USED FOR INFILTRATION AFTER CONSTRUCTION SHALL NOT BE USED AS BMPs DURING CONSTRUCTION UNLESS OTHERWISE APPROVED IN WRITING BY THE ENGINEER AND THE TOWN OF STURBRIDGE. MANY INFILTRATION TECHNOLOGIES ARE NOT DESIGNED TO HANDLE THE HIGH CONCENTRATIONS OF SEDIMENTS TYPICALLY FOUND IN CONSTRUCTION RUNOFF, AND THUS MUST BE PROTECTED FROM CONSTRUCTION RELATED SEDIMENT LOADINGS.
13. SOIL STOCKPILES MUST BE STABILIZED OR COVERED AT THE END OF EACH WORKDAY. STOCKPILE SIDE SLOPES SHALL NOT BE GREATER THAN 2:1. ALL STOCKPILES SHALL BE SURROUNDED BY SEDIMENT CONTROLS.
14. FOR ACTIVE CONSTRUCTION AREAS SUCH AS BORROW OR STOCKPILE AREAS, ROADWAY IMPROVEMENTS AND AREAS WITHIN 50 FEET OF A BUILDING UNDER CONSTRUCTION, A PERIMETER SEDIMENT CONTROL SYSTEM SHALL BE INSTALLED AND MAINTAINED TO CONTAIN SOIL.

EROSION AND SEDIMENT CONTROL NOTES (CONT.):

15. A TRACKING PAD OR OTHER APPROVED STABILIZATION METHOD SHALL BE CONSTRUCTED AT ALL ENTRANCE/EXITS POINTS OF THE SITE TO REDUCE THE AMOUNT OF SOIL CARRIED ONTO ROADWAYS AND OFF THE SITE.
16. ON THE CUT SIDE OF ROADS, DITCHES SHALL BE STABILIZED IMMEDIATELY WITH ROCK RIP-RAP OR OTHER NON-ERODIBLE LINERS, OR WHERE APPROPRIATE, VEGETATIVE MEASURES SUCH AS HYDROSEEDING OR JUTE MATTING.
17. PERMANENT SEEDING SHALL BE UNDERTAKEN IN THE SPRING FROM MARCH THROUGH MAY, AND IN LATE SUMMER AND EARLY FALL FROM AUGUST TO OCTOBER 15. DURING THE PEAK SUMMER MONTHS AND IN THE FALL AFTER OCTOBER 15, WHEN SEEDING IS FOUND TO BE IMPRACTICAL, APPROPRIATE TEMPORARY STABILIZATION SHALL BE APPLIED. PERMANENT SEEDING MAY BE UNDERTAKEN DURING THE SUMMER IF PLANS PROVIDE FOR ADEQUATE MULCHING AND WATERING.
18. ALL SLOPES STEEPER THAN 3:1 (H:V, 33.3%), AS WELL AS PERIMETER DIKES, SEDIMENT BASINS OR TRAPS, AND EMBANKMENTS MUST, UPON COMPLETION, BE IMMEDIATELY STABILIZED WITH SOD, SEED AND ANCHORED STRAW MULCH, OR OTHER APPROVED STABILIZATION MEASURES. AREAS OUTSIDE OF THE PERIMETER SEDIMENT CONTROL SYSTEM MUST NOT BE DISTURBED.
19. TEMPORARY SEDIMENT TRAPPING DEVICES MUST NOT BE REMOVED UNTIL PERMANENT STABILIZATION IS ESTABLISHED IN ALL CONTRIBUTORY DRAINAGE AREAS.
20. ALL TEMPORARY EROSION AND SEDIMENT CONTROL MEASURES SHALL BE REMOVED AFTER FINAL SITE STABILIZATION. DISTURBED SOIL AREAS RESULTING FROM THE REMOVAL OF TEMPORARY MEASURES SHALL BE PERMANENTLY STABILIZED WITHIN 30 DAYS OF REMOVAL.
21. PROPERLY MANAGE ON-SITE CONSTRUCTION AND WASTE MATERIALS.
22. PREVENT OFF-SITE VEHICLE TRACKING OF SEDIMENTS.
23. DUST SHALL BE CONTROLLED AT THE SITE.
24. ALL PREVIOUSLY DISTURBED LAND SHALL BE STABILIZED BY APPROVED METHODS AFTER 14 DAYS IF LEFT UNDISTURBED, THIS INCLUDES STOCKPILES, CONSTRUCTION ENTRANCES, GRADED AREAS AND OTHER CONSTRUCTION ACTIVITY RELATED CLEARING.
25. IF WORK IS HALTED OVER WINTER MONTHS THE CONTRACTOR SHALL BE RESPONSIBLE FOR STABILIZING THE AREA THROUGH GROUND COVER PRACTICES.

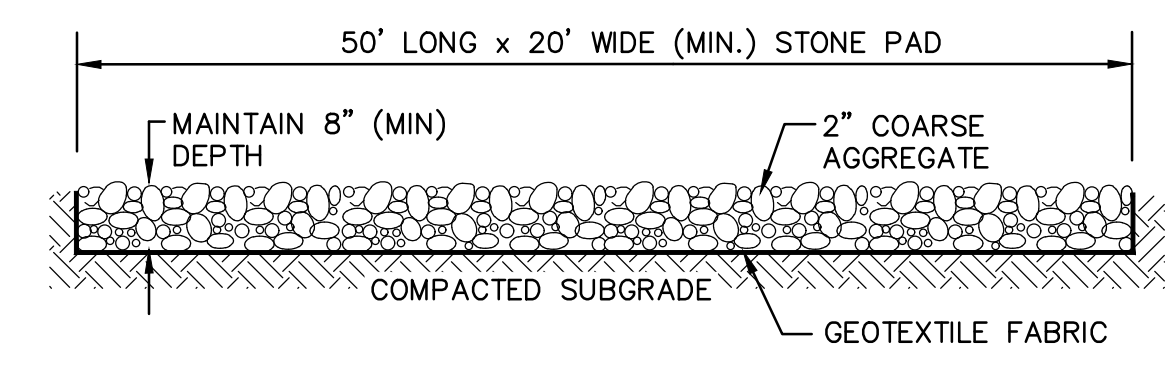

TEMPORARY CONSTRUCTION ENTRANCE

SCALE: NONE

REVISIONS:

NO.	DATE	DESC.
1	11/15/23	PER PEER REVIEW

**ISSUED FOR PERMITTING
NOT FOR CONSTRUCTION**

PREPARED FOR:
STURBRIDGE PV, LLC
2420 17TH STREET
DENVER, CO 80202

BSC GROUP
349 Main Street - Route 28
West Yarmouth, Massachusetts
02673
508 778 8919

© 2022 BSC Group, Inc.
SCALE: 1" = 50'
0 25 50 100 FEET

FILE: PROJECTS-YAR\5074500\C\5074500-SP.dwg
DWG: DWG
JOB: NO: 5-0745.00
SHEET 3 OF 9

GENERAL NOTES

1. THE AREA ENCLOSED BY CHAIN LINK FENCE IS 8.48± ACRES.
2. CONSTRUCTION OF THE PROPOSED SITE IMPROVEMENTS REQUIRES THE CLEARING OF 9.30± ACRES OF WOODLANDS.
3. ALL DISTURBED AREAS WITHIN THE CHAIN LINK FENCE, IF NOT OTHERWISE SPECIFIED, WILL BE LOAMED AND SEEDING WITH A POLLINATOR SEED MIXTURE.

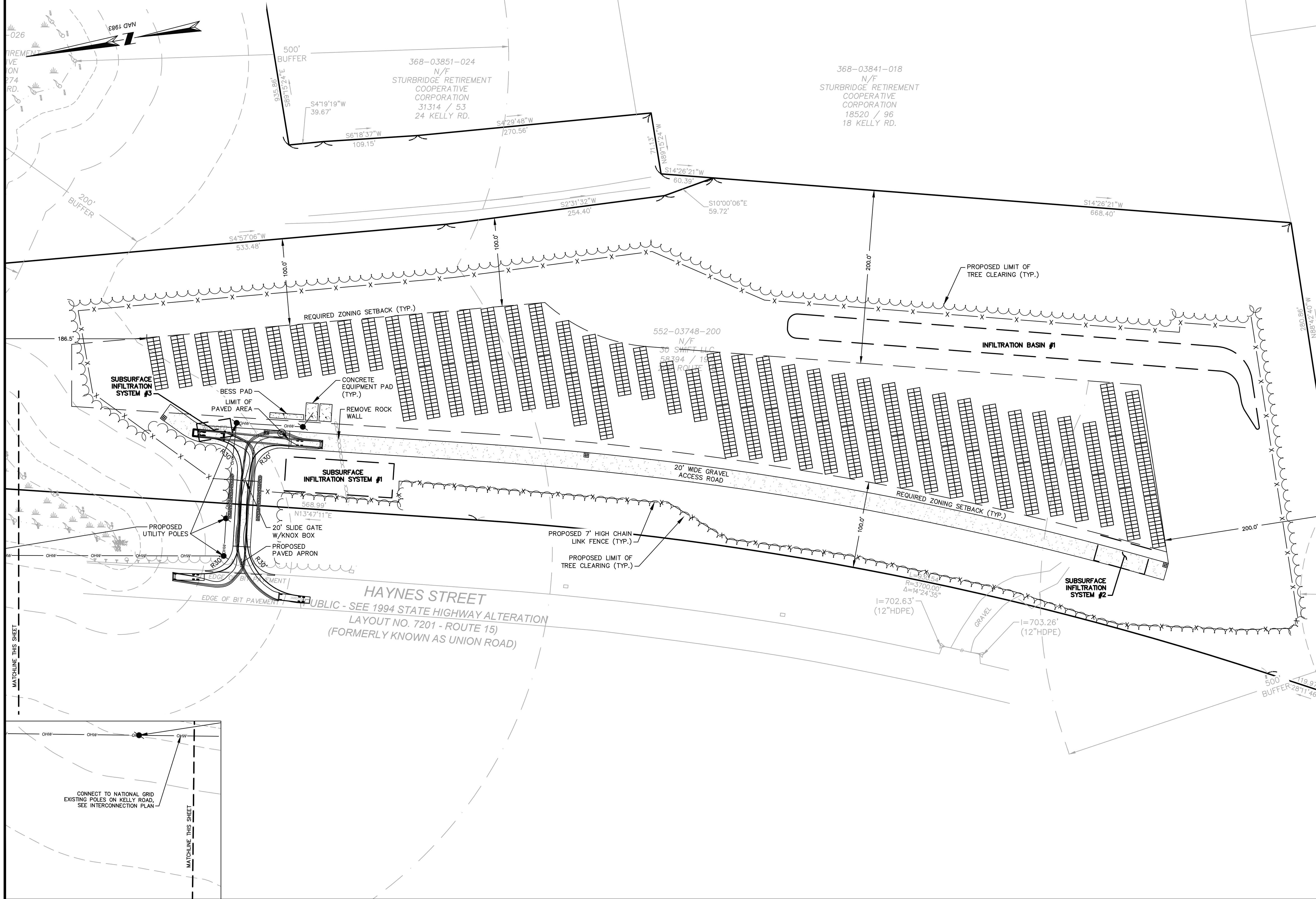

11/15/23

BRIAN G. YERGATIAN
PROFESSIONAL ENGINEER

GROUND-MOUNTED PHOTOVOLTAIC SYSTEM

200 ROUTE 15

IN

STURBRIDGE
MASSACHUSETTS
(WORCESTER COUNTY)

LAYOUT & MATERIALS PLAN

AUGUST 1, 2023

REVISIONS:

NO.	DATE	DESC.
1	11/15/23	PER PEER REVIEW

**ISSUED FOR PERMITTING
NOT FOR CONSTRUCTION**

PREPARED FOR:
STURBRIDGE PV, LLC
2420 17TH STREET
DENVER, CO 80202

BSC GROUP
349 Main Street - Route 28
West Yarmouth, Massachusetts
02673
508 778 8919

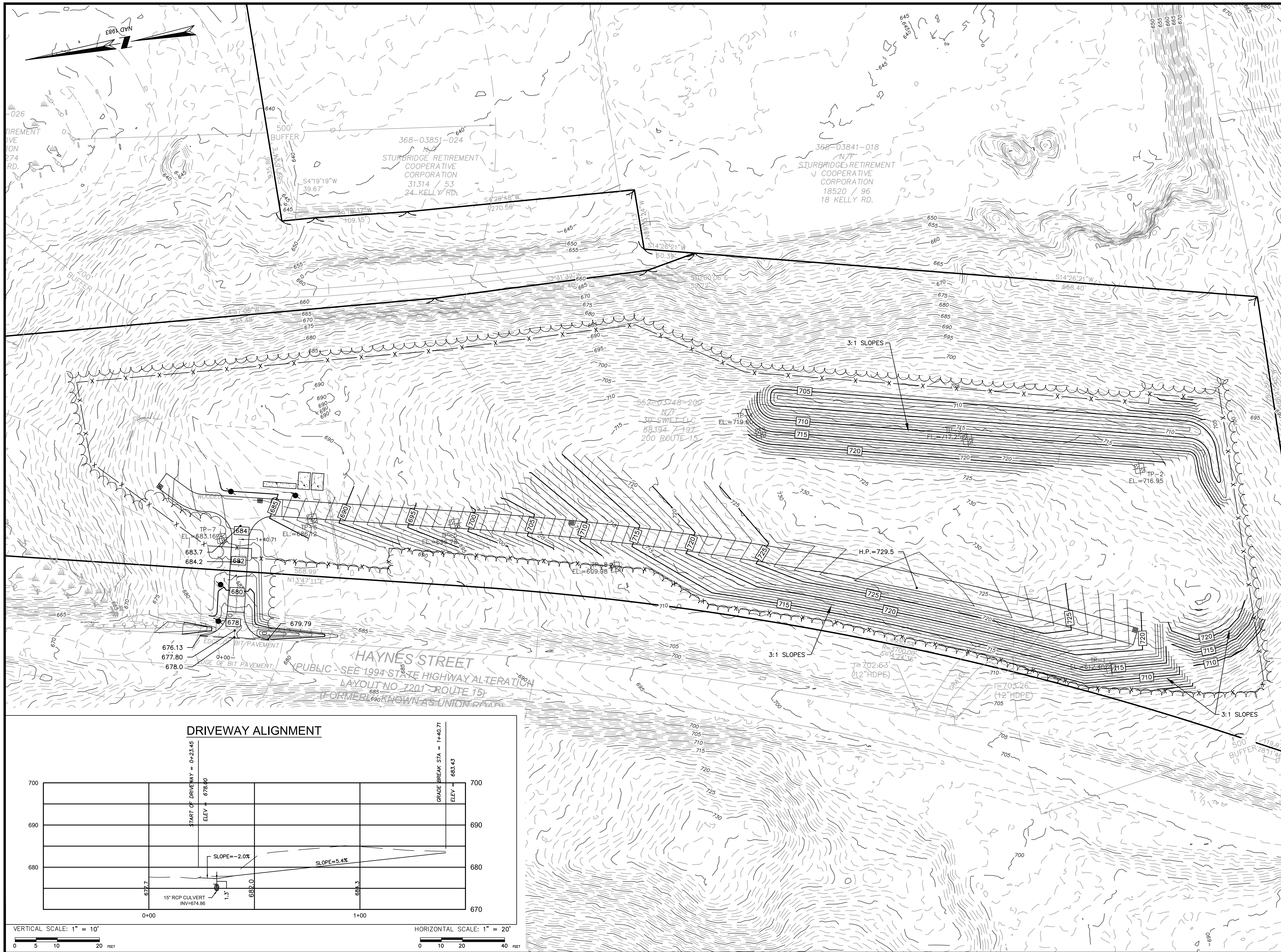

11/15/23

BRIAN G. YERGATIAN
PROFESSIONAL ENGINEER

**GROUND-MOUNTED
PHOTOVOLTAIC
SYSTEM**

200 ROUTE 15
IN
STURBRIDGE
MASSACHUSETTS
(WORCESTER COUNTY)

GRADING PLAN

AUGUST 1, 2023

REVISIONS:

NO.	DATE	DESC.
1	11/15/23	PER PEER REVIEW

**ISSUED FOR PERMITTING
NOT FOR CONSTRUCTION**

PREPARED FOR:
STURBRIDGE PV, LLC
2420 17TH STREET
DENVER, CO 80202

BSC GROUP
349 Main Street - Route 28
West Yarmouth, Massachusetts
02673
508 778 8919

© 2022 BSC Group, Inc.
SCALE: 1" = 50'
0 25 50 100 FEET

FILE: PROJECTS-YAR\5074500\C\5074500-SP.dwg
DWG: DWG
JOB: NO: 5-0745.00 SHEET 5 OF 9



11/15/23

BRIAN G. YERGATIAN
PROFESSIONAL ENGINEER DATE

GROUND-MOUNTED PHOTOVOLTAIC SYSTEM
200 ROUTE 15
IN
STURBRIDGE MASSACHUSETTS (WORCESTER COUNTY)

DRAINAGE PLAN

AUGUST 1, 2023

REVISIONS:

NO.	DATE	DESC.
1	11/15/23	PER PEER REVIEW

**ISSUED FOR PERMITTING
NOT FOR CONSTRUCTION**

PREPARED FOR:
STURBRIDGE PV, LLC
2420 17TH STREET
DENVER, CO 80202

BSC GROUP
349 Main Street - Route 28
West Yarmouth, Massachusetts
02673
508 778 8919

© 2022 BSC Group, Inc.
SCALE: 1" = 50'
0 25 50 100 FEET

FILE: PROJECTS-YAR\5074500\C\5074500-SP.dwg
DWG: DWG SHEET 6 OF 9
JOB: NO: 5-0745.00

- EXAMINATION OF CONDITIONS:**
- THE CONTRACTOR SHALL BE RESPONSIBLE FOR JUDGING THE FULL EXTENT OF WORK REQUIREMENTS INVOLVED. THIS RESPONSIBILITY INCLUDES, BUT IS NOT LIMITED TO, THE FOLLOWING: TRANSPORTATION, PURCHASE, TEMPORARY STORAGE AND MAINTENANCE OF PLANTS; PLANT RE-HANDLING PRIOR TO FINAL INSTALLATION; REMOVAL AND OFF-SITE DISPOSAL OF EXISTING LOAM DETERMINED BY THE ENGINEER TO BE UNACCEPTABLE; PURCHASE, TRANSPORT, AND SUPPLY OF LOAM.
 - IMPORTED LOAM OFTEN CARRIES ANNUAL WEED SEED SUCH AS PERISCARIA. IT IS ADVANTAGEOUS TO ALLOW SOIL TO SETTLE AND WEED SEED TO GERMINATE AND BE MOVED PRIOR TO SITE SEEDING.
 - VERIFY ALL EXISTING UTILITY LINES PRIOR TO PLANTING AND REPORT ANY CONFLICTS TO THE OWNER OR HIS REPRESENTATIVE.
- PLANTING NOTES:**
- ALL PLANT MATERIAL SHALL CONFORM TO THE MINIMUM GUIDELINES ESTABLISHED BY THE AMERICAN STANDARD FOR NURSERY STOCK PUBLISHED BY THE AMERICAN ASSOCIATION OF NURSERYMEN, INC.
 - PLANT MATERIALS SHALL BEAR SAME RELATIONSHIP TO GRADE AS THEY BORE TO GRADE IN THE NURSERY.
 - ALL TREES NOTED FOR CLEARING AND SELECTIVE PRUNING AND THINNING SHALL BE EXECUTED UNDER THE SUPERVISION OF A LICENSED ARBORIST.
 - THE CONTRACTOR SHALL CLEARLY MARK LIMITS OF CLEARING AND LIMITS OF SELECTIVE PRUNING AND THINNING, FOR REVIEW BY THE A/E PRIOR TO ANY CLEARING OPERATIONS. VEGETATION THAT IS NOT USED IN HABITAT FEATURES OR REMOVED AS TIMBER PRODUCTS SHALL BE CHIPPED ON SITE AND INCORPORATED INTO TOP SOIL.
 - THE CONTRACTOR SHALL TAKE ALL MEASURES NECESSARY TO PROTECT EXISTING VEGETATION THAT IS TAGGED BY THE A/E, TO BE SAVED.
 - ALL TREES TO BE SAVED SHALL BE PROTECTED WITH MARKED BOUNDS AT A MINIMUM DISTANCE OF 6', OR AS DIRECTED BY THE LANDSCAPE ARCHITECT.
 - THE A/E RESERVES THE RIGHT TO ADJUST FINAL GRADES IN THE FIELD TO SAVE EXISTING VEGETATION.
 - LOAM AND SEED ALL DISTURBED AREAS UNLESS OTHERWISE INDICATED.
 - THE LANDSCAPE CONTRACTOR SHALL FURNISH TOPSOIL. TOPSOIL SHALL BE FERTILE, FRABLE, NATURAL AND PRODUCTIVE TOPSOIL OF GOOD CLAY-LOAM TYPE. IT SHALL BE FREE OF WEED SEEDS. TOPSOIL SHALL BE WITHOUT ADMIXTURE OF SUBSOIL AND SHALL BE REASONABLY FREE OF STONES, LUMPS, ROOTS, STICKS AND OTHER FOREIGN MATTER. TOPSOIL SHALL NOT BE WORKED OR APPLIED IN A MUDDY OR WET CONDITION.
 - STOCKPILE ROCKS, STUMPS, LOGS AND ORGANIC DEBRIS FROM SOIL SURFACE AS HABITAT AND GRADE TO AN UNEVEN SURFACE.

- MAINTENANCE PERIOD: 90 DAYS**
- THE MAINTENANCE PERIOD SHALL BEGIN IMMEDIATELY AFTER EACH PLANT IS PLANTED AND SHALL CONTINUE FOR A MINIMUM OF 90 DAYS FOLLOWING THE COMPLETION OF ALL PLANTING INSTALLATIONS, OR UNTIL THE CONDITIONAL ACCEPTANCE OF ALL PLANTING WORK, WHICHEVER IS A LONGER PERIOD OF TIME.
 - AT THE END OF THE MAINTENANCE PERIOD, THE CONTRACTOR WILL REQUEST INSPECTION BY THE OWNERS REPRESENTATIVE AT LEAST 10 DAYS BEFORE THE ANTICIPATED DATE OF INSPECTION.
 - AT THE TIME OF INSPECTION, IF THE PLANT MATERIALS AND WORKMANSHIP ARE ACCEPTABLE TO THE LANDSCAPE ARCHITECTS, THEY SHALL ISSUE A WRITTEN CERTIFICATE OF CONDITIONAL ACCEPTANCE TO THE CONTRACTOR. THE DATE OF THE INSPECTION SHALL ESTABLISH THE END OF THE MAINTENANCE PERIOD AND THE COMMENCEMENT OF THE REQUIRED ONE-YEAR ESTABLISHMENT PERIOD FOR PLANTING WORK.
 - IF IN THE LANDSCAPE ARCHITECTS OPINION, PLANT MATERIALS AND/OR WORKMANSHIP IS DEFICIENT, ACCEPTANCE WILL NOT BE GRANTED, AND THE MAINTENANCE PERIOD FOR ALL THE PLANTS SHALL BE EXTENDED UNTIL PLANT REPLACEMENTS ARE MADE OR OTHER DEFICIENCIES ARE CORRECTED. ALL DEAD AND UNSATISFACTORY PLANTS WILL BE REMOVED PROMPTLY FROM THE PROJECT. REPLACEMENT PLANTS SHALL CONFORM IN ALL RESPECTS TO THE SPECIFICATIONS FOR THE ORIGINAL PLANTS AND SHALL BE PLANTED IN THE SAME MANNER.
- ESTABLISHMENT PERIOD: ONE YEAR**
- THE PURPOSE OF THE ESTABLISHMENT PERIOD IS TO NURTURE PLANTS AND SEEDING THROUGH AT LEAST ONE FULL GROWING SEASON AND ONE FULL WINTER. ALL PLANTS SHALL BE INSPECTED BY THE ENGINEER ONE YEAR AFTER CONDITIONAL ACCEPTANCE AND SHALL BE ALIVE AND IN SATISFACTORY GROWTH AT THE END OF THAT TIME. THE CONTRACTOR IS RESPONSIBLE FOR ARRANGING INSPECTION EARLY ENOUGH IN THE SEASON TO ALLOW ADEQUATE TIME TO PROCURE AND INSTALL REPLACEMENT MATERIAL.
 - AT THE END OF THE ESTABLISHMENT PERIOD, EACH PLANT/ SEED TYPE SHALL SHOW HEALTHY GROWTH ON AT LEAST 75 PERCENT OF ITS TERMINAL STEMS, AS DETERMINED BY THE ENGINEER. DETERMINATION OF HEALTHY GROWTH SHALL INCLUDE, BUT IS NOT NECESSARILY LIMITED TO, VISIBLE LEAVES (ON SEASON) AND TERMINAL BUDS. PLANTS FOUND TO BE UNACCEPTABLE SHALL BE REMOVED PROMPTLY FROM THE SITE AND REPLACED IMMEDIATELY OR DURING THE NEXT NORMAL PLANTING SEASON, OR RE-SEED AS PERMITTED BY THE SPECIFICATIONS.
 - THE LANDSCAPE ARCHITECT WILL INSPECT THE REPLACEMENT PLANTING WORK UPON THE REQUEST OF THE CONTRACTOR. REQUEST FOR INSPECTION SHALL BE RECEIVED BY THE LANDSCAPE ARCHITECTS AT LEAST TEN DAYS BEFORE THE ANTICIPATED DATE OF INSPECTION.

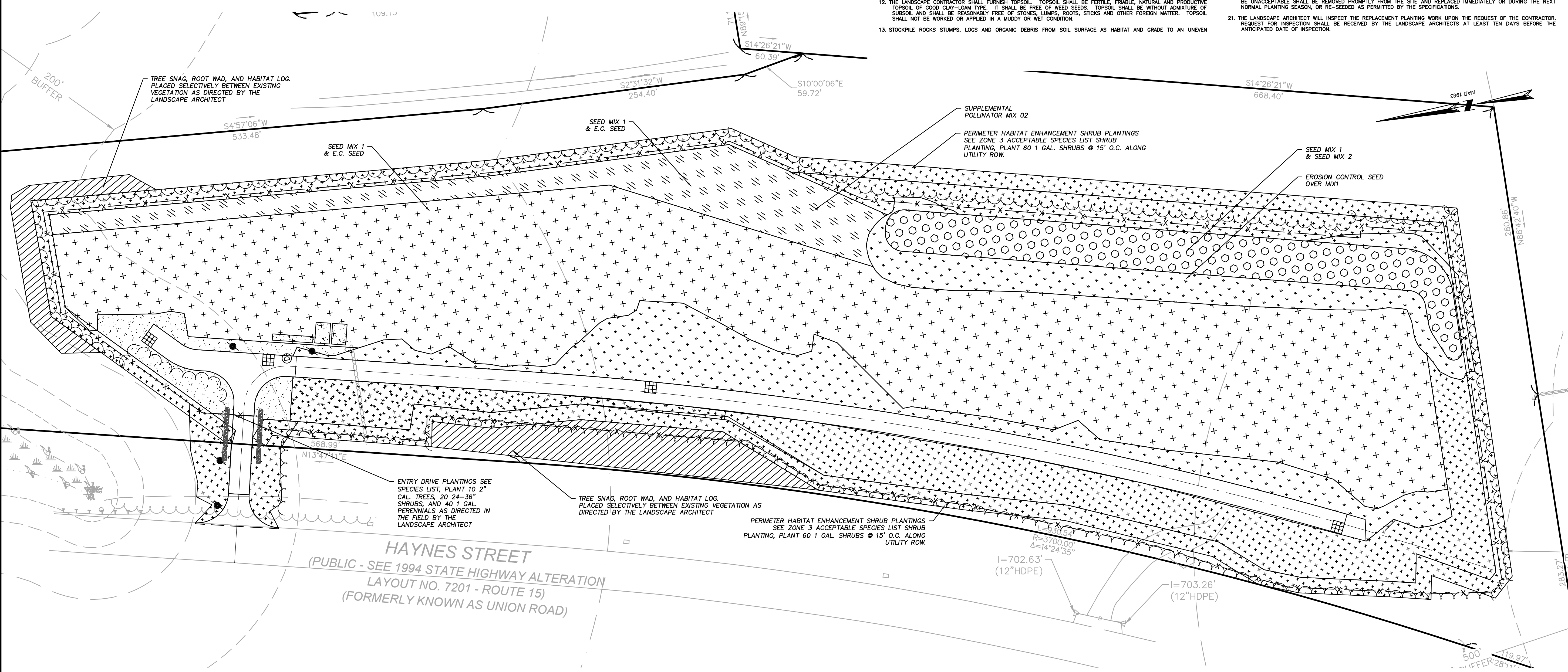

11/15/23

BRIAN G. YERGATIAN
PROFESSIONAL ENGINEER

GROUND-MOUNTED PHOTOVOLTAIC SYSTEM

200 ROUTE 15
IN
STURBRIDGE MASSACHUSETTS (WORCESTER COUNTY)

PLANTING PLAN

AUGUST 1, 2023

REVISIONS:

NO.	DATE	DESC.
1	11/15/23	PER PEER REVIEW

**ISSUED FOR PERMITTING
NOT FOR CONSTRUCTION**

PREPARED FOR:
STURBRIDGE PV, LLC
2420 17TH STREET
DENVER, CO 80202

BSC GROUP

349 Main Street - Route 28
West Yarmouth, Massachusetts
02673
508 778 9919

© 2022 BSC Group, Inc.
SCALE: 1" = 50'
0 25 50 100 FEET

FILE: PROJECTS-YAR\5074500\C\5074500-SP.dwg
DWG: DWG
JOB. NO: 5-0745.00
SHEET 7 OF 9

- BASE SEED MIXES**
POLLINATOR MIXES ARE BEST SPREAD BY BROADCASTING USING A CYCLONE FERTILIZER SPREADER PRIOR TO HYDROSEEDING OR HYDROMULCHING. BROADCASTING NATIVE WARM-SEASON GRASS AND FORB SEED ARE IRREGULAR AND REQUIRE THE USE OF A CARRIER TO ENSURE THE MIXTURE FLOWS CORRECTLY THROUGH THE SPREADER AND THE SEED IS DISTRIBUTED EVENLY ACROSS THE FIELD.
- COVER CROP HYDROSEEDED OVER BASE SEED DURING ESTABLISHMENT**
ALL SEEDING AREAS TO BEGIN WITH A COVER CROP SELECTED RELATIVE TO SEASON SEED AT 20 LBS/ACRE WITH A COVER CROP FOR A COVER CROP USE JAPANESE MILLET (10 LBS/ACRE; 1 MAY TO 31 AUG), BARNYARD GRASS (10 LBS/ACRE; 1 MAY TO 31 AUG), OR GRAIN RYE (30 LBS/ACRE; 1 SEPT TO 30 APR).
- LOW UPLAND POLLINATOR MIX 1 UNDER ARRAY UNDER 3' PART SHADE**
1 LB/ 1000 FT.
ERNMX-612 OR EQUIVALENT
94.9% FESTUCA OVINA, (SHEEP FESCUE)
2.5% ASCLEPIAS TUBEROSA (BUTTERFLY MILKWEED)
2.0% CHAMAECRISTA FASCICULATA, PA ECOTYPE (PARTRIDGE PEA)
0.3% OENOTHERA FRUTICOSA VAR. FRUTICOSA (SUNDROPS)
0.3% SISYRINCHUM ANGSTUFOLIUM (NARROWLEAF BLUE EYED GRASS)
- EROSION CONTROL SEED (OVER MIX 1 FOR STEEP SLOPES) UNDER 3'**
2 LB/ 1000 FT.
70% LOLIUM PERENNE, TETRAPLOID (PERENNIAL RYEGRASS, TETRAPLOID)
30% AVENA SATIVA, (OATS)
- POLLINATOR FRIENDLY TURF**
4 LB/ 1000 FT.
ERNMX-186
LOW GRASS MIX WITH RED AND WHITE CLOVER
- BASIN MIX 2 OUTSIDE ARRAY FULL SUN TRANSITIONAL MOISTURE**
1 LB/ 1000 FT.
ERNMX-610
37.0% SCHIZACHYRIUM SCOPARIUM, (LITTLE BLUESTEM)
36.3% BOULETELOUA CURTIPENDULA, BUTTE (SIDEOTS GRAMA, BUTTE)
4.0% CHAMAECRISTA FASCICULATA, (PARTRIDGE PEA)
4.0% COREOPSIS LANOECLATA (LANCELEAF COREOPSIS)
4.0% ECHINACEA PURPUREA (PURPLE CONEFLOWER)
3.3% RUDBECKIA HIRTA (BLACKEYED SUSAN)
2.3% HELIOPSIS HELIANTHOIDES, (OXEYE SUNFLOWER)
1.6% NASTEMON DIGITALIS (TALL WHITE BEARDTONGUE)
1.5% ASCLEPIAS TUBEROSA (BUTTERFLY MILKWEED)
0.8% LIATRIS SPICATA (MARSH BLAZING STAR)
0.7% SENNA HEBECARPA, (WILD SENNA)
0.6% ZIZIA AUREA (GOLDEN ALEXANDERS)
0.5% ASCLEPIAS INCARNATA, (SWAMP MILKWEED)
0.5% GEUM CANADENSE, (WHITE AVENS)
0.5% MONARDA FISTULOSA, (WILD BERGAMOT)
0.5% PYNANTHEMUM TENUFOLIUM (NARROWLEAF MOUNTAINMINT)
0.4% ASTER LAEVIS, NY ECOTYPE (SMOOTH BLUE ASTER, NY ECOTYPE)
0.4% ASTER NOVAE-ANGLIAE, (NEW ENGLAND ASTER)
0.3% BAPTISIA AUSTRALIS, SOUTHERN BLUE FALSE INDIGO, SOUTHERN
0.3% SISYRINCHUM ANGSTUFOLIUM (NARROWLEAF BLUE EYED GRASS)
0.2% OENOTHERA FRUTICOSA VAR. FRUTICOSA (SUNDROPS)
0.2% SOLIDAGO NEMORALIS, (GRAY GOLDENROD)
0.1% ASTER PRENANTHOIDES, (GIZGAG ASTER)
- POLLINATOR MIX 2 OUTSIDE ARRAY FULL SUN UNDER 4'**
1 LB/ 1000 FT.
ERNMX-148 OR EQUIVALENT
26.4% LOLIUM PERENNE, TETRAPLOID (PERENNIAL RYEGRASS, TETRAPLOID)
21.0% DACTYLIS GLOMERATA, POTOMAC (ORCHARDGRASS, POTOMAC)
18.9% POA PRATENSIS, 'GINGER' (KENTUCKY BLUEGRASS, 'GINGER' (PASTURE TYPE)
12.0% BROMUS BIBERSTEINI, 'FLEET' (MEADOW BROME, 'FLEET')
5.7% TRIFOLIUM HYBRIDUM (ALSKA CLOVER)
5.0% FESTUCA ELATIOR X LOLIUM PERENNE, DUO (FESTULOLIUM, DUO)
4.8% TRIFOLIUM PRATENSE, MEDIUM, (RED CLOVER, MEDIUM)
2.0% LOTUS CORNICULATUS, 'LEO' (BIRD'S FOOT TREFLOIL, 'LEO')
1.4% CHAMAECRISTA FASCICULATA, (PARTRIDGE PEA,)
1.0% LINUM PERENNE (PERENNIAL BLUE FLAX)
0.9% COREOPSIS LANOECLATA (LANCELEAF COREOPSIS)
0.5% CHRYSANTHEMUM LEUCANTHEMUM (OXEYE DAISY)
0.4% SOLIDAGO NEMORALIS, (GRAY GOLDENROD)
- SHADE PERIMETER POLLINATOR MIX**
1 LB/ 1000 FT.
ERNMX-132-1
29.0% PANICUM CLANDESTINUM, TIOPA (DEERTONGUE, TIOPA)
20.0% LOLIUM MULTIFLORUM (ANNUAL RYEGRASS)
15.0% ELYMUS VIRGINICUS, MADISON-NY ECOTYPE (VIRGINIA WILDRYE,
15.0% PANICUM VIRGATUM, 'SHELTER' (SWITCHGRASS, 'SHELTER')
10.0% FESTUCA RUPEA (CREEPING RED FESCUE)
5.0% AGROSTIS PERENNANS, ALBANY PINE (AUTUMN BENTGRASS)
3.0% CAREX VULPINOIDEA, (FOX SEDGE)
3.0% CHAMAECRISTA FASCICULATA, (PARTRIDGE PEA)

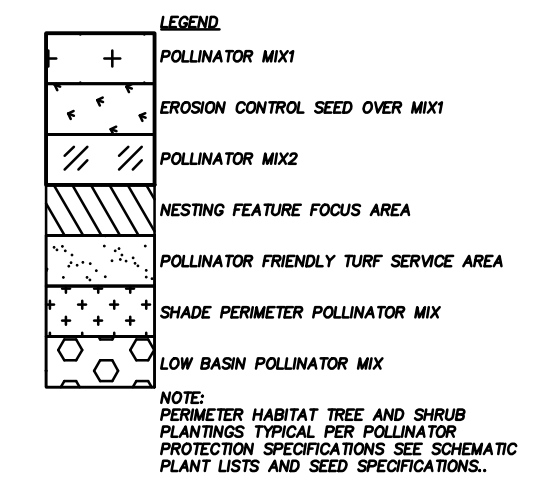

ACCEPTABLE FILL MATERIALS: STORMTECH SC-740 CHAMBER SYSTEMS

MATERIAL LOCATION	DESCRIPTION	AASHTO MATERIAL CLASSIFICATIONS	COMPACTION / DENSITY REQUIREMENT
D	FINAL FILL: FILL MATERIAL FOR LAYER 'D' STARTS FROM THE TOP OF THE 'C' LAYER TO THE BOTTOM OF FLEXIBLE PAVEMENT OR UNPAVED FINISHED GRADE ABOVE. NOTE THAT PAVEMENT SUBBASE MAY BE PART OF THE 'D' LAYER.	N/A	PREPARE PER SITE DESIGN ENGINEER'S PLANS. PAVED INSTALLATIONS MAY HAVE STRINGENT MATERIAL AND PREPARATION REQUIREMENTS.
C	INITIAL FILL: FILL MATERIAL FOR LAYER 'C' STARTS FROM THE TOP OF THE EMBEDMENT STONE ('B' LAYER) TO 18" (450 mm) ABOVE THE TOP OF THE CHAMBER. NOTE THAT PAVEMENT SUBBASE MAY BE A PART OF THE 'C' LAYER.	AASHTO M14S' A-1, A-2.4, A-3 OR AASHTO M43' 3, 357, 4, 467, 5, 56, 57, 6, 67, 68, 7, 78, 8, 89, 9, 10	BEGIN COMPACTIONS AFTER 12" (300 mm) OF MATERIAL OVER THE CHAMBERS IS REACHED. COMPACT ADDITIONAL LAYERS IN 6" (150 mm) MAX LIFTS TO A MIN. 95% PROCTOR DENSITY FOR WELL GRADED MATERIAL AND 95% RELATIVE DENSITY FOR PROCESSED AGGREGATE MATERIALS. ROLLER GROSS VEHICLE WEIGHT NOT TO EXCEED 12,000 lbs (53 kN). DYNAMIC FORCE NOT TO EXCEED 20,000 lbs (89 kN).
B	EMBEDMENT STONE: FILL SURROUNDING THE CHAMBERS FROM THE FOUNDATION STONE ('A' LAYER) TO THE 'C' LAYER ABOVE.	AASHTO M43' 3, 357, 4, 467, 5, 56, 57	NO COMPACTION REQUIRED.
A	FOUNDATION STONE: FILL BELOW CHAMBERS FROM THE SUBGRADE UP TO THE FOOT (BOTTOM) OF THE CHAMBER.	AASHTO M43' 3, 357, 4, 467, 5, 56, 57	FLATE COMPACT OR ROLL TO ACHIEVE A FLAT SURFACE. ^{2,3}

PLEASE NOTE:
 1. THE LISTED AASHTO DESIGNATIONS ARE FOR GRADATIONS ONLY. THE STONE MUST ALSO BE CLEAN, CRUSHED, ANGULAR. FOR EXAMPLE, A SPECIFICATION FOR #4 STONE WOULD STATE: "CLEAN, CRUSHED, ANGULAR NO. 4 (AASHTO M43) STONE."
 2. STORMTECH COMPACTION REQUIREMENTS ARE MET FOR 'A' LOCATION MATERIALS WHEN PLACED AND COMPACTED IN 6" (150 mm) (MAX) LIFTS USING TWO FULL COVERAGES WITH A VIBRATORY COMPACTOR.
 3. WHERE INFILTRATION SURFACES MAY BE COMPROMISED BY COMPACTION, FOR STANDARD DESIGN LOAD CONDITIONS, A FLAT SURFACE MAY BE ACHIEVED BY RAKING OR DRAGGING WITHOUT COMPACTION EQUIPMENT. FOR SPECIAL LOAD DESIGNS, CONTACT STORMTECH FOR COMPACTION REQUIREMENTS.
 4. ONCE LAYER 'C' IS PLACED, ANY SOIL/MATERIAL CAN BE PLACED IN LAYER 'D' UP TO THE FINISHED GRADE. MOST PAVEMENT SUBBASE SOILS CAN BE USED TO REPLACE THE MATERIAL REQUIREMENTS OF LAYER 'C' OR 'D' AT THE SITE DESIGN ENGINEER'S DISCRETION.

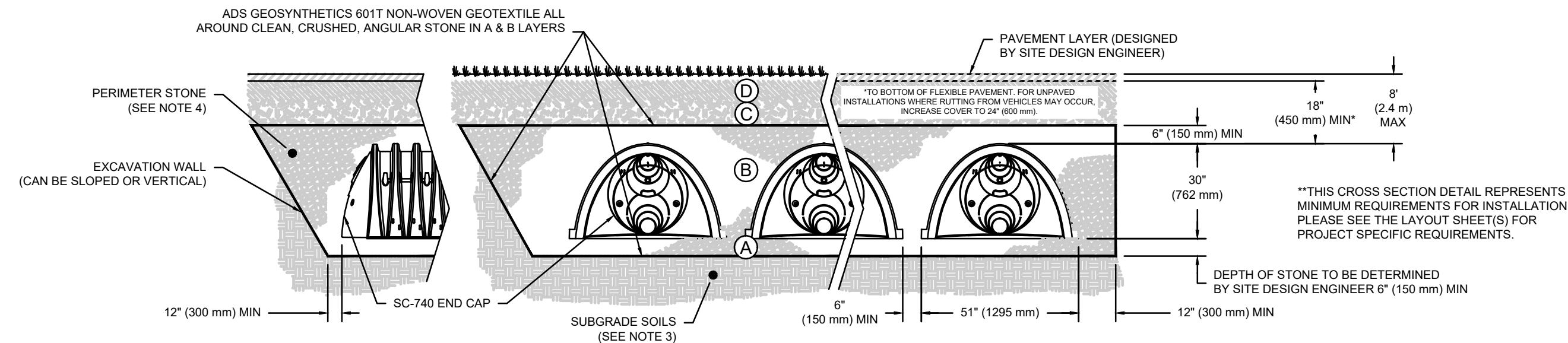

NOTES:

- CHAMBERS SHALL MEET THE REQUIREMENTS OF ASTM F2418, "STANDARD SPECIFICATION FOR POLYPROPYLENE (PP) CORRUGATED WALL STORMWATER COLLECTION CHAMBERS".
- SC-740 CHAMBERS SHALL BE DESIGNED IN ACCORDANCE WITH ASTM F2787 "STANDARD PRACTICE FOR STRUCTURAL DESIGN OF THERMOPLASTIC CORRUGATED WALL STORMWATER COLLECTION CHAMBERS".
- THE SITE DESIGN ENGINEER IS RESPONSIBLE FOR ASSESSING THE BEARING RESISTANCE (ALLOWABLE BEARING CAPACITY) OF THE SUBGRADE SOILS AND THE DEPTH OF FOUNDATION STONE WITH CONSIDERATION FOR THE RANGE OF EXPECTED SOIL MOISTURE CONDITIONS.
- PERIMETER STONE MUST BE EXTENDED HORIZONTALLY TO THE EXCAVATION WALL FOR BOTH VERTICAL AND SLOPED EXCAVATION WALLS.
- REQUIREMENTS FOR HANDLING AND INSTALLATION:
 - TO MAINTAIN THE WIDTH OF CHAMBERS DURING SHIPPING AND HANDLING, CHAMBERS SHALL HAVE INTEGRAL, INTERLOCKING STACKING LUGS.
 - TO ENSURE A SECURE JOINT DURING INSTALLATION AND BACKFILL, THE HEIGHT OF THE CHAMBER JOINT SHALL NOT BE LESS THAN 2".
 - TO ENSURE THE INTEGRITY OF THE ARCH SHAPE DURING INSTALLATION, THE ARCH STIFFNESS CONSTANT AS DEFINED IN SECTION 6.2.8 OF ASTM F2418 SHALL BE GREATER THAN OR EQUAL TO 550 LBS/FT². AND b) TO RESIST CHAMBER DEFORMATION DURING INSTALLATION AT ELEVATED TEMPERATURES (ABOVE 73° F / 23° C), CHAMBERS SHALL BE PRODUCED FROM REFLECTIVE GOLD OR YELLOW COLORS.

1 SC-740 CROSS SECTION DETAIL

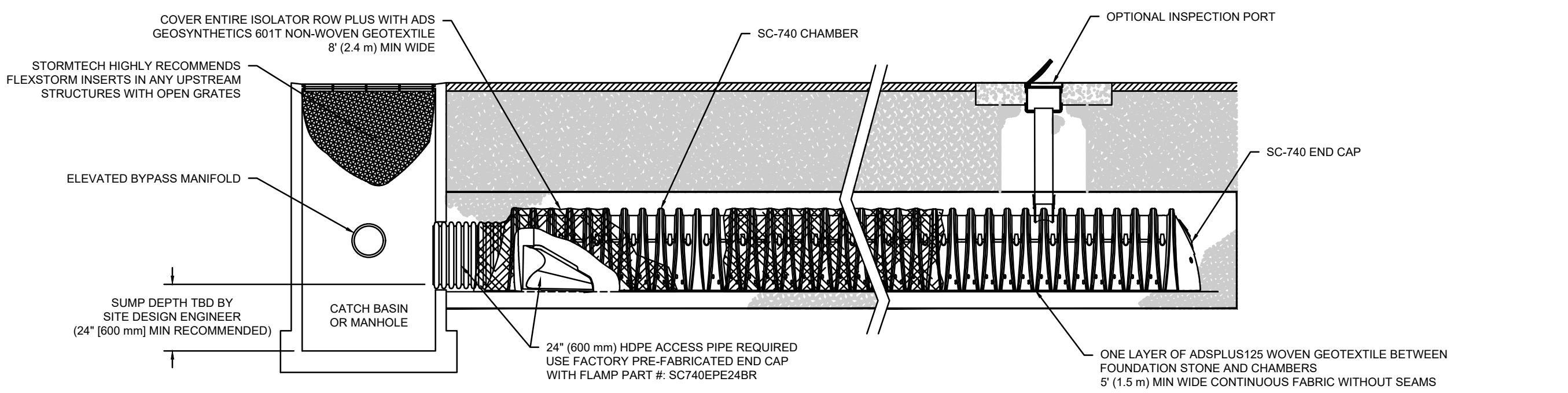

3 SC-740 ISOLATOR ROW PLUS DETAIL

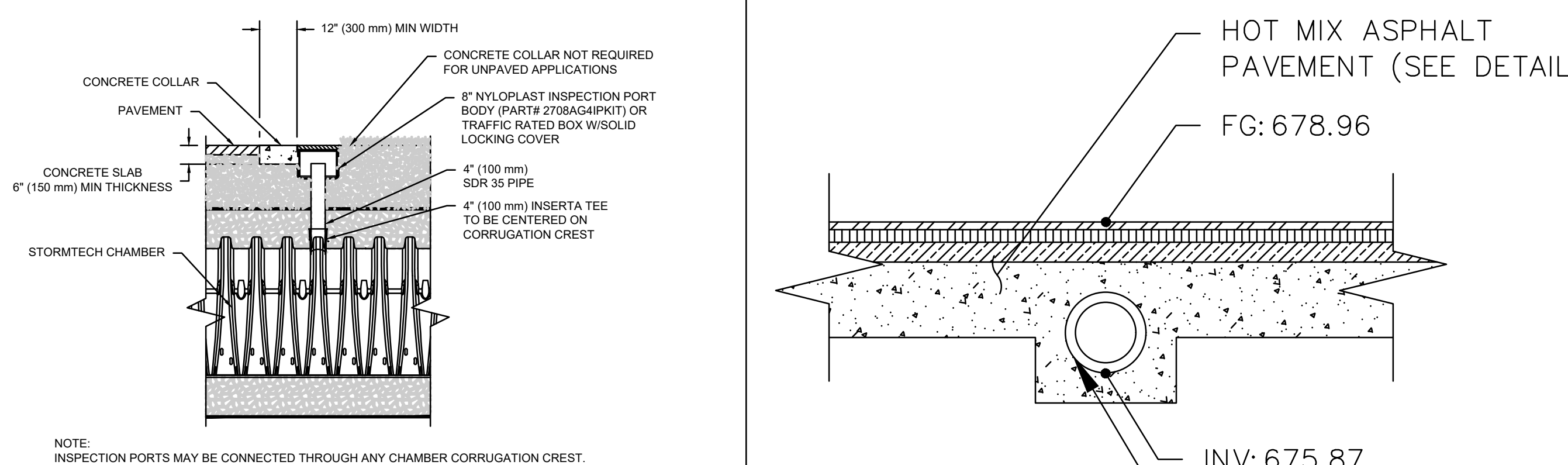

4 4\"/>

INFILTRATION BASIN #1

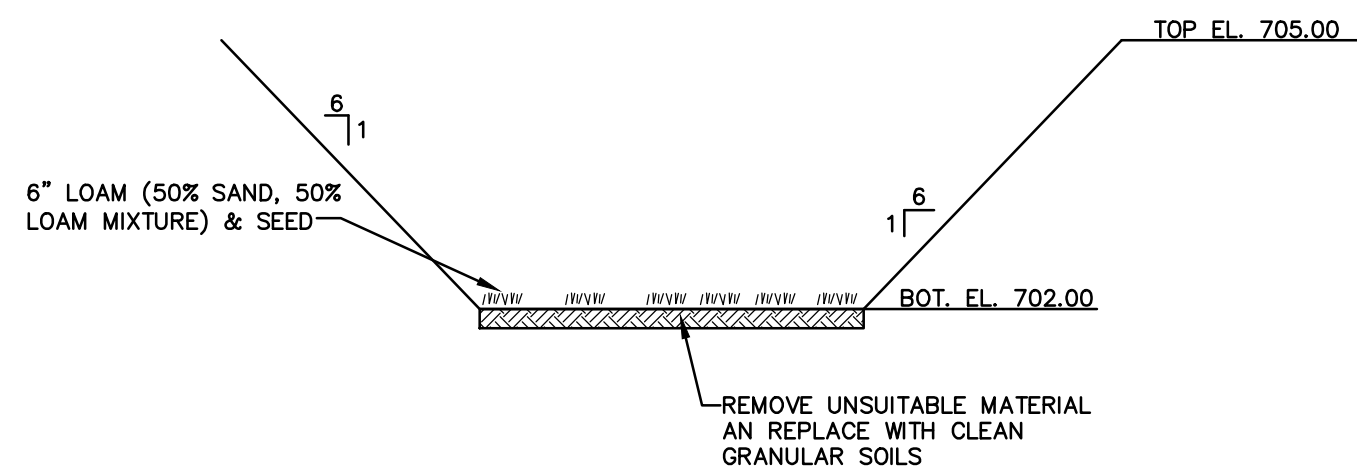

NOTES:

- LIGHT EARTH MOVING EQUIPMENT IS TO BE USED DURING CONSTRUCTION TO REDUCE COMPACTION OF BASIN BOTTOM.
- BASIN FLOOR IS TO BE DEEPLY TILLED AFTER FINAL GRADING.
- PROPER EROSION SEDIMENT CONTROLS SHOULD BE UTILIZED DURING CONSTRUCTION TO PREVENT SEDIMENT AND/OR DEBRIS FROM ENTERING THE BASIN.
- 75% OF RIP-RAP STONE SHALL BE 70 - 100 lbs.

INFILTRATION BASIN CROSS-SECTION

SCALE: NONE

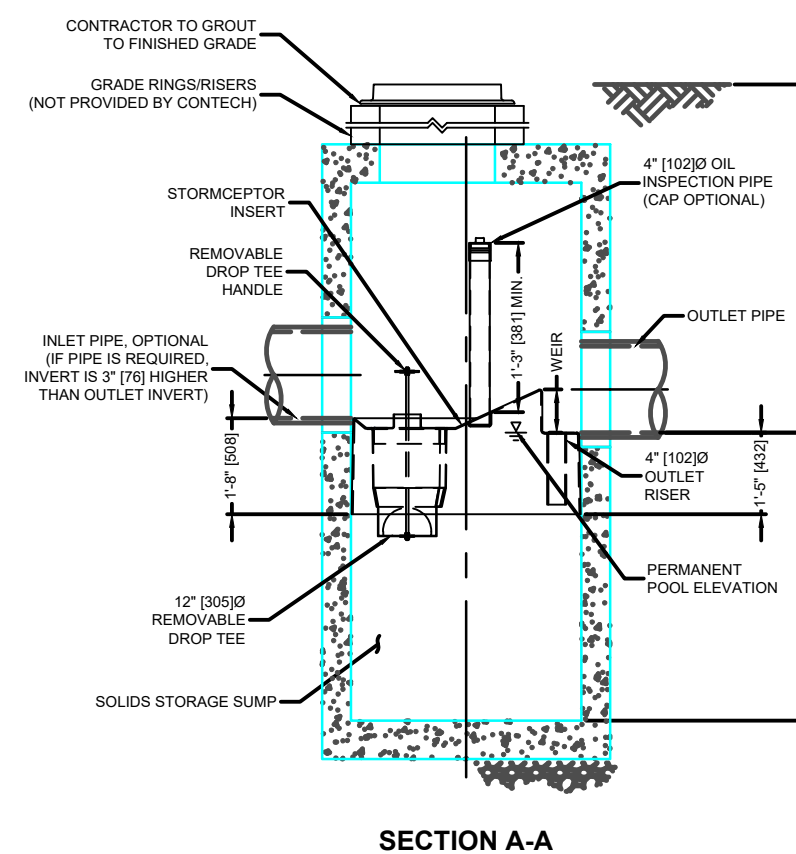

SECTION A-A

GENERAL NOTES:

- CONTECH TO PROVIDE ALL MATERIALS UNLESS NOTED OTHERWISE.
- FOR SITE SPECIFIC DRAWINGS WITH DETAILED STRUCTURE DIMENSIONS AND WEIGHT, PLEASE CONTACT YOUR CONTECH ENGINEERED SOLUTIONS LLC REPRESENTATIVE. www.contechES.com
- STORMCEPTOR WATER QUALITY STRUCTURE SHALL BE IN ACCORDANCE WITH ALL DESIGN DATA AND INFORMATION CONTAINED IN THIS DRAWING. CONTRACTOR TO CONFIRM STRUCTURE MEETS REQUIREMENTS OF PROJECT.
- STORMCEPTOR STRUCTURE SHALL MEET AASHTO H2020 LOAD RATING, ASSUMING EARTH COVER OF 0' - 2' (610), AND GROUNDWATER ELEVATION AT OR BELOW THE OUTLET PIPE INVERT ELEVATION. ENGINEER OF RECORD TO CONFIRM ACTUAL GROUNDWATER ELEVATION. CASTINGS SHALL MEET AASHTO M309 AND BE CAST WITH THE CONTECH LOGO.
- STORMCEPTOR STRUCTURE SHALL BE PRECAST CONCRETE CONFORMING TO ASTM C478 AND AASHTO LOAD FACTOR DESIGN METHOD.
- ALTERNATE UNITS ARE SHOWN IN MILLIMETERS (mm).

STORMCEPTOR STC 450i

SCALE: NONE

PLACE TUBE AS CLOSE TO LIMIT OF SOIL DISTURBANCE AS POSSIBLE, ALONG CONTOURS, AND PERPENDICULAR TO FLOW.
 ADJUST LOCATION AS REQUIRED FOR OPTIMUM EFFECTIVENESS. DO NOT INSTALL IN WATERWAYS.

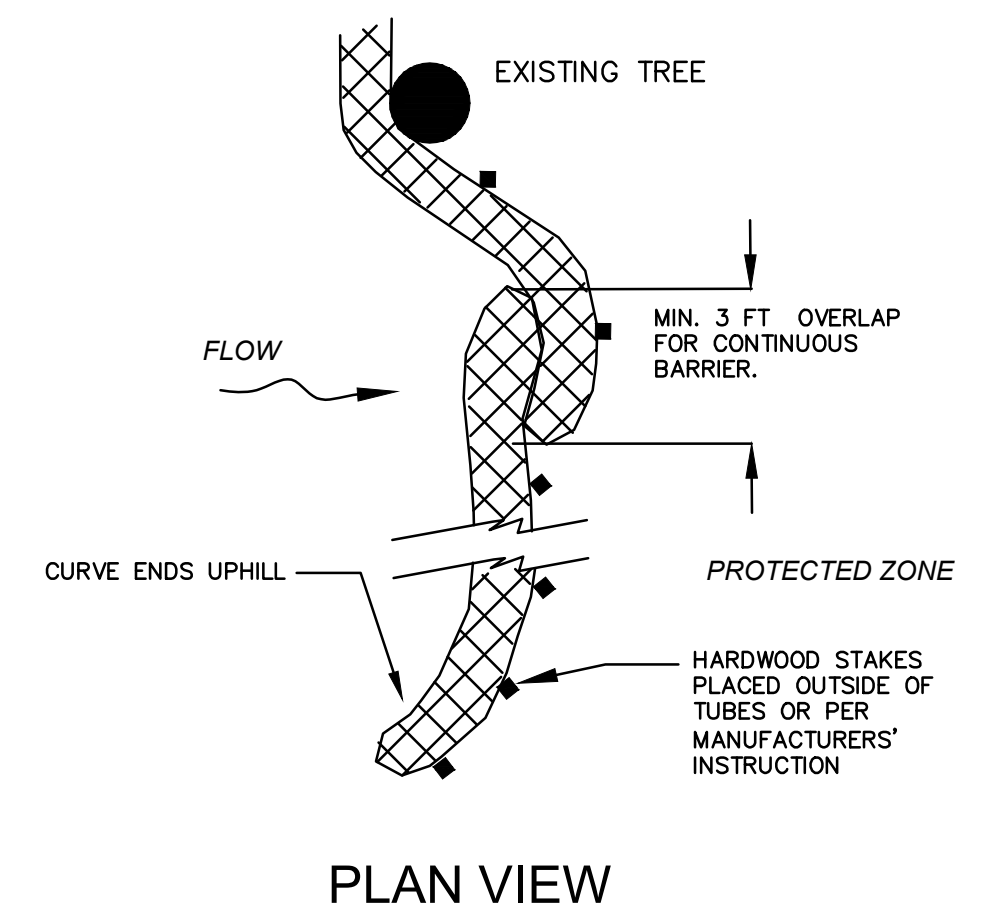

PLAN VIEW

SILTSOXX COMPOST FILTER SOCK WITH SILT FENCE BACKING

SCALE: NONE

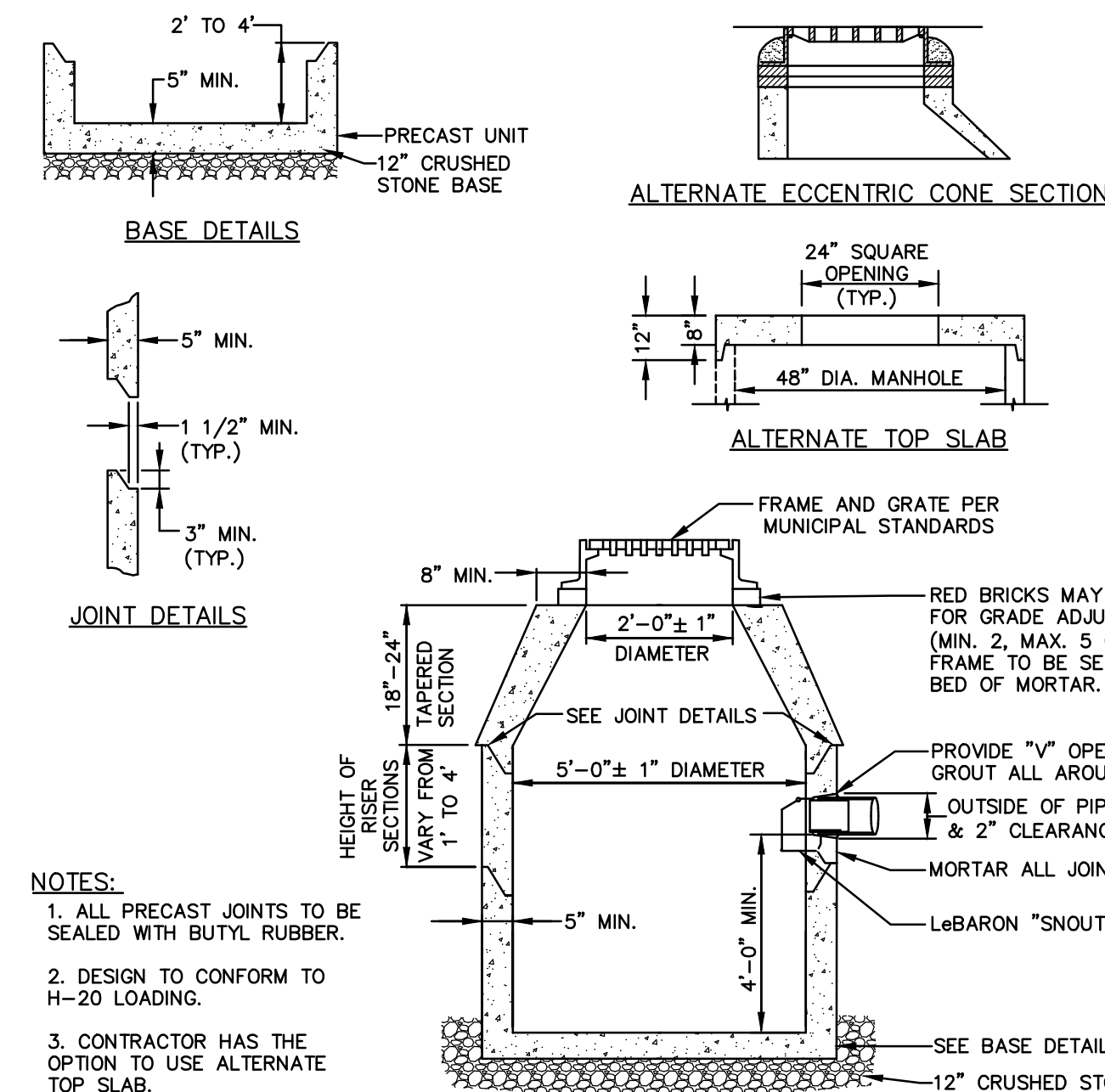

PRECAST CONCRETE CATCH BASIN

SCALE: NONE

NOTES:

- ALL PRECAST JOINTS TO BE SEALED WITH BUTYL RUBBER.
- DESIGN TO CONFORM TO H-20 LOADING.
- CONTRACTOR HAS THE OPTION TO USE ALTERNATE TOP SLAB.

PLAN VIEW

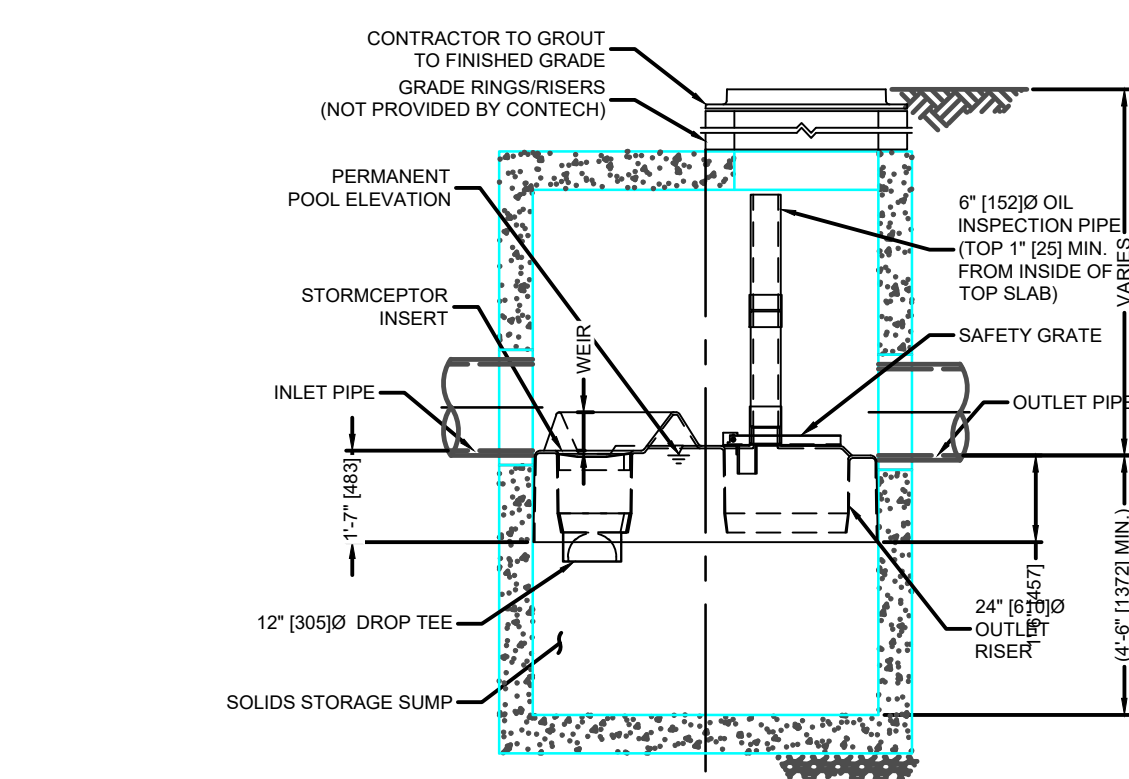

SECTION A-A

GENERAL NOTES:

- CONTECH TO PROVIDE ALL MATERIALS UNLESS NOTED OTHERWISE.
- FOR SITE SPECIFIC DRAWINGS WITH DETAILED STRUCTURE DIMENSIONS AND WEIGHT, PLEASE CONTACT YOUR CONTECH ENGINEERED SOLUTIONS LLC REPRESENTATIVE. www.contechES.com
- STORMCEPTOR WATER QUALITY STRUCTURE SHALL BE IN ACCORDANCE WITH ALL DESIGN DATA AND INFORMATION CONTAINED IN THIS DRAWING. CONTRACTOR TO CONFIRM STRUCTURE MEETS REQUIREMENTS OF PROJECT.
- STORMCEPTOR STRUCTURE SHALL MEET AASHTO H2020 LOAD RATING, ASSUMING EARTH COVER OF 0' - 2' (610), AND GROUNDWATER ELEVATION AT OR BELOW THE OUTLET PIPE INVERT ELEVATION. ENGINEER OF RECORD TO CONFIRM ACTUAL GROUNDWATER ELEVATION. CASTINGS SHALL MEET AASHTO M309 AND BE CAST WITH THE CONTECH LOGO.
- STORMCEPTOR STRUCTURE SHALL BE PRECAST CONCRETE CONFORMING TO ASTM C478 AND AASHTO LOAD FACTOR DESIGN METHOD.
- ALTERNATE UNITS ARE SHOWN IN MILLIMETERS (mm).

STORMCEPTOR STC 900

SCALE: NONE

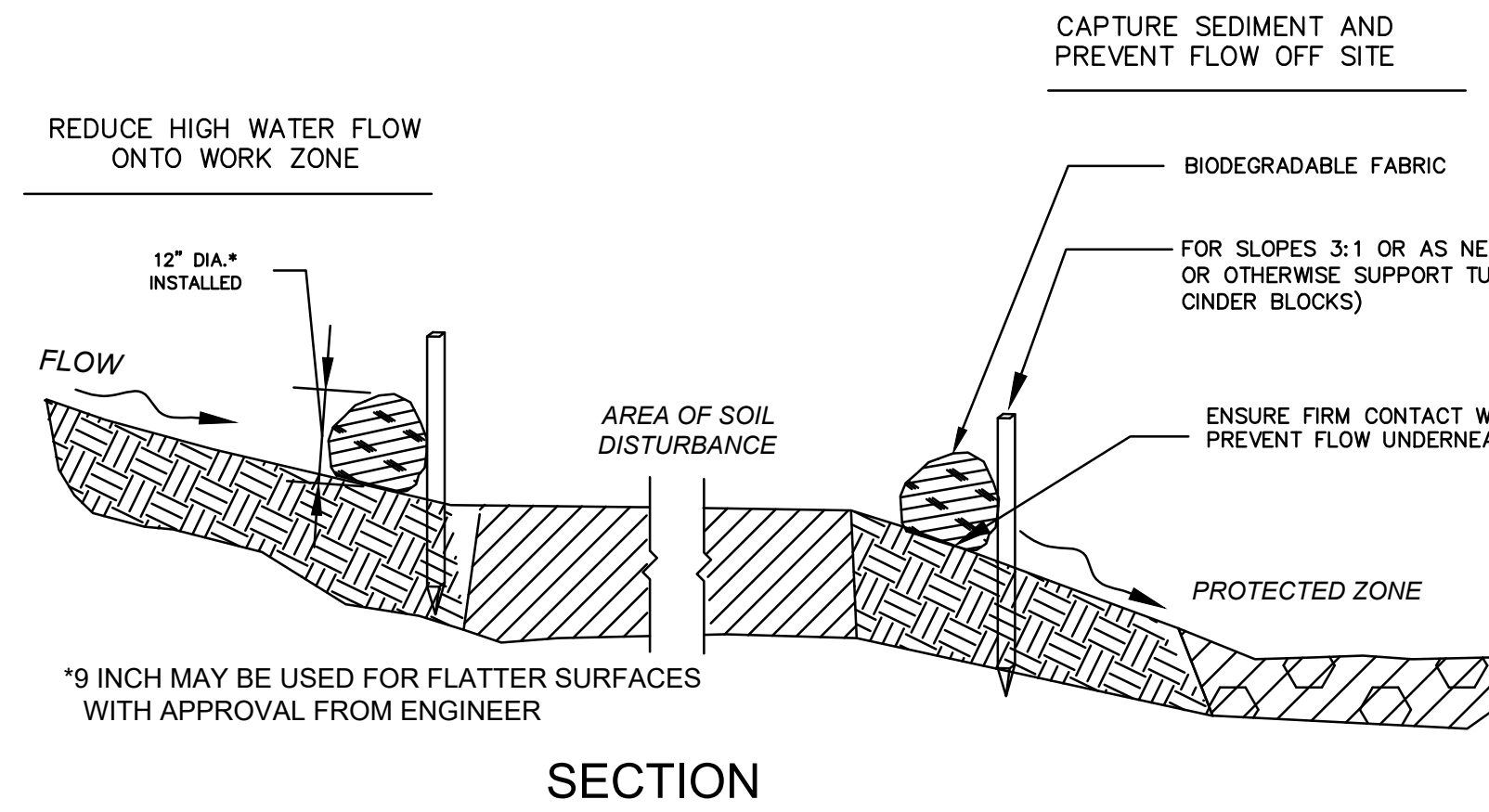

SECTION



BRIAN G. YERGATIAN DATE
 PROFESSIONAL ENGINEER

11/15/23

GROUND-MOUNTED PHOTOVOLTAIC SYSTEM

200 ROUTE 15

IN
 STURBRIDGE
 MASSACHUSETTS
 (WORCESTER COUNTY)

DETAIL SHEET

AUGUST 1, 2023

REVISIONS:

NO.	DATE	DESC.
1	11/15/23	PER PEER REVIEW

**ISSUED FOR PERMITTING
 NOT FOR CONSTRUCTION**

PREPARED FOR:
 STURBRIDGE PV, LLC
 2420 17TH STREET
 DENVER, CO 80202

BSC GROUP
 349 Main Street - Route 28
 West Yarmouth, Massachusetts
 02673
 508 778 8919

© 2022 BSC Group, Inc.
 SCALE: NOT TO SCALE

FILE: PROJECTS-YAR\5074500\C\5074500-SP.dwg
 DWG: DWG
 JOB: NO: 5-0745.00 SHEET 8 OF 9

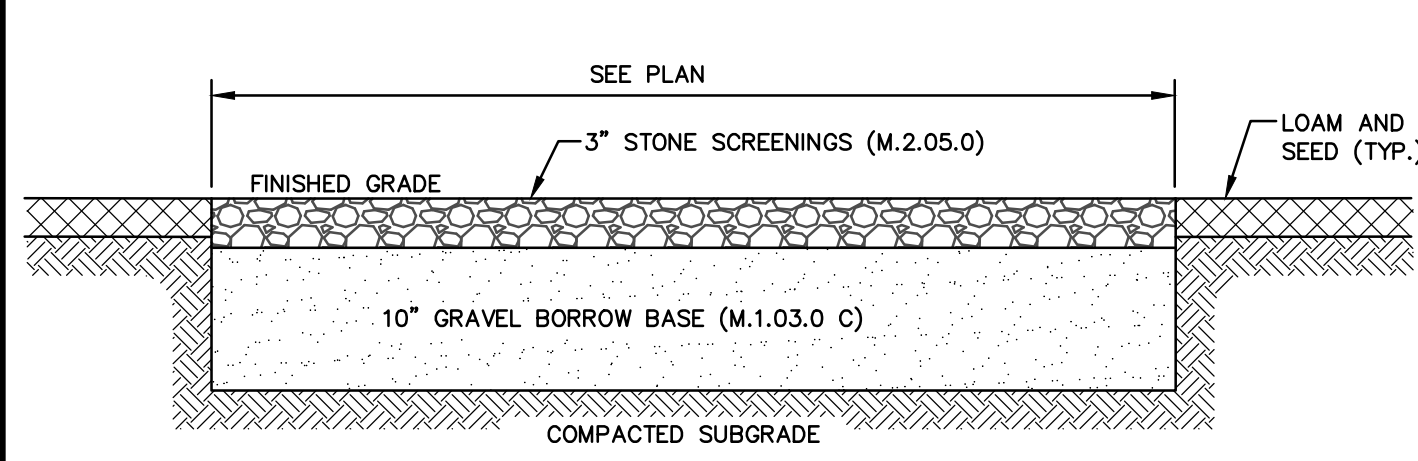

GRAVEL DRIVEWAY
SCALE: NONE

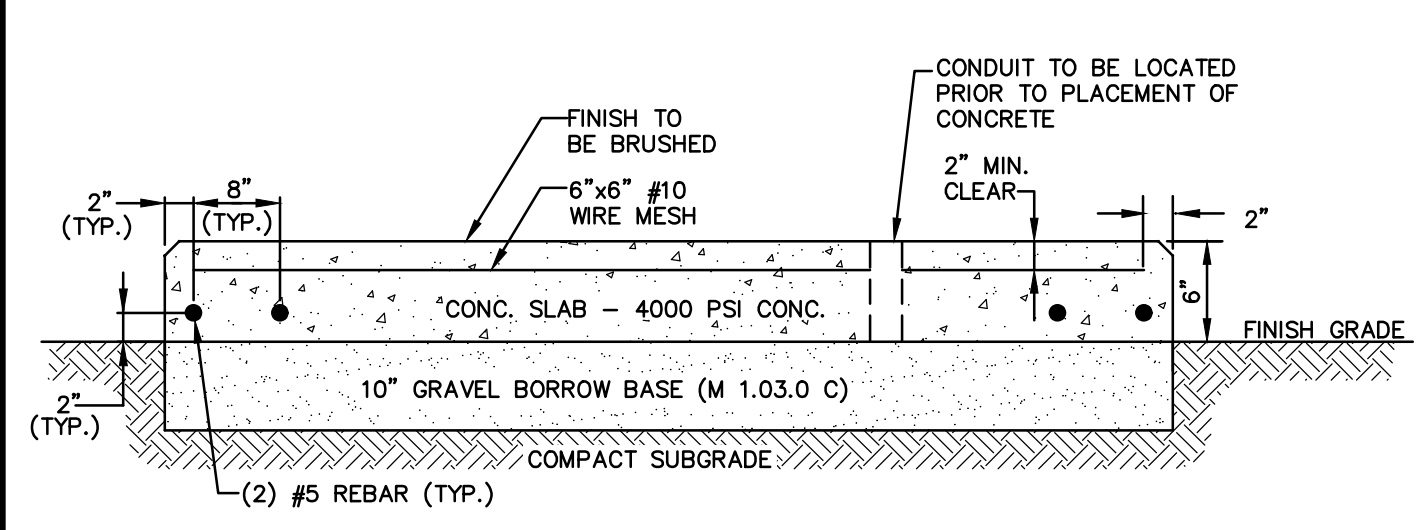

TRANSFORMER PAD
SCALE: NONE

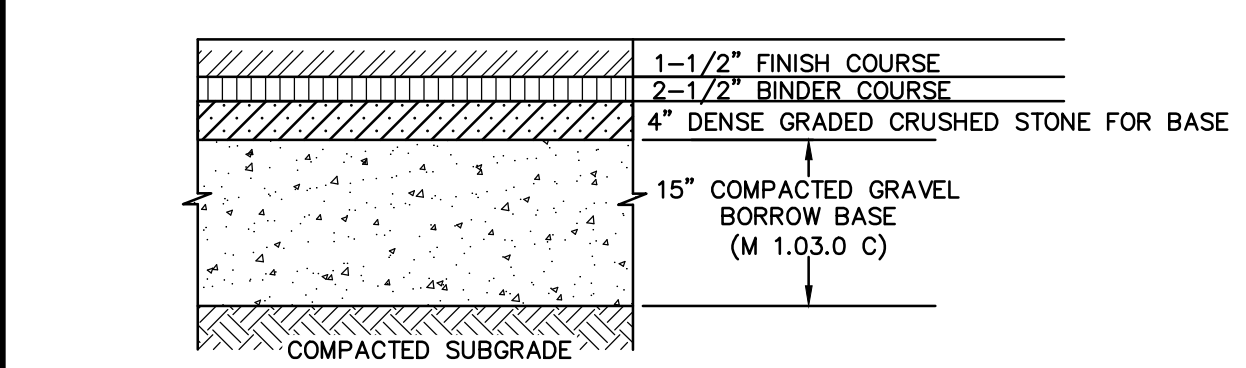

STANDARD DUTY FLEXIBLE PAVEMENT

NOTE:
PAVEMENT SECTIONS ARE SUBJECT TO CHANGE AND MAY BE BASED ON THE RESULTS OF GEOTECHNICAL INVESTIGATIONS

HOT MIX ASPHALT PAVEMENT SECTIONS
SCALE: NONE

CHAIN LINK FENCE FRAMEWORK SCHEDULE

FABRIC HEIGHT	6' OR LESS	6' - 10'	10' OR MORE
END, CORNER & PULL POST	2.375" O.D.	2.875" O.D.	4" O.D.
LINE POST	1.900" O.D.	2.375" O.D.	2.875" O.D.
TOP AND BOTTOM RAIL	1.660" O.D.	1.660" O.D.	1.660" O.D.
MIDDLE RAIL	NONE	1.660" O.D.	1.660" O.D.

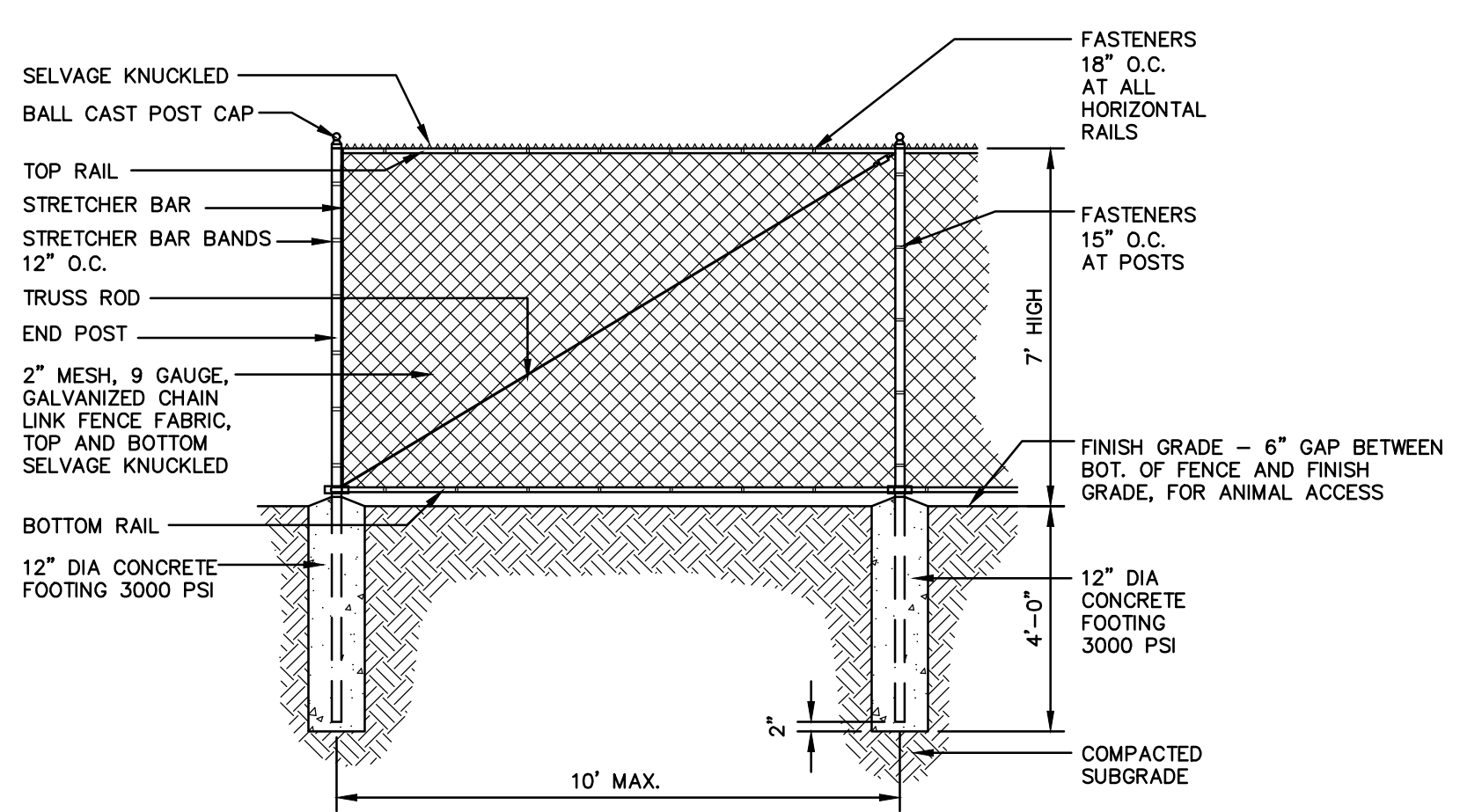

CHAIN LINK FENCE
SCALE: NONE

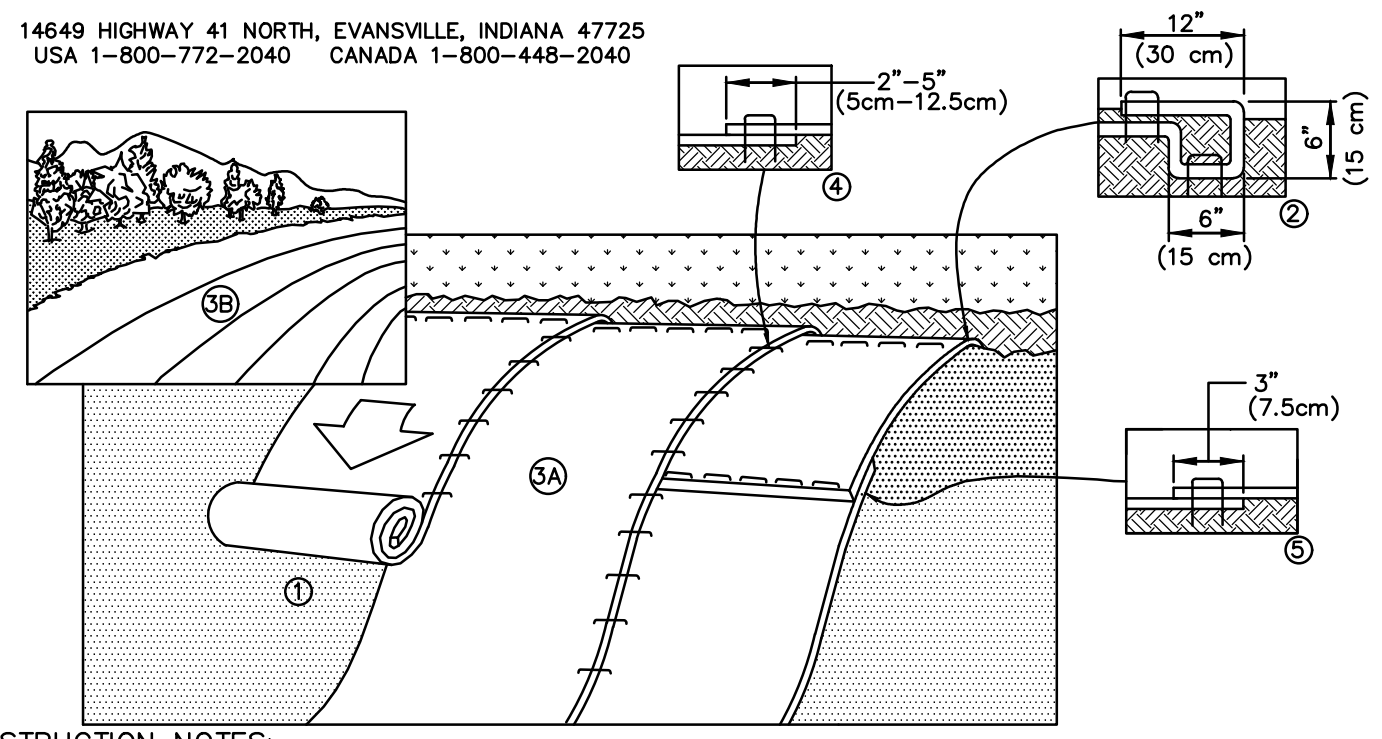

- CONSTRUCTION NOTES:**
1. PREPARE SOIL BEFORE INSTALLING BLANKETS, INCLUDING ANY NECESSARY APPLICATION OF LIME, FERTILIZER, AND SEED. HYDROSEED SIDE SLOPES BEFORE INSTALLATION OF BLANKETS.
 2. BEGIN AT THE TOP OF THE SLOPE BY ANCHORING THE BLANKET IN A 6" (15cm) DEEP X 6" (15cm) WIDE TRENCH WITH APPROXIMATELY 12" (30cm) OF BLANKET EXTENDED BEYOND THE UP-SLOPE PORTION OF THE TRENCH. ANCHOR THE BLANKET WITH A ROW OF STAPLES/STAKES APPROXIMATELY 12" (30cm) APART IN THE BOTTOM OF THE TRENCH. BACKFILL AND COMPACT THE TRENCH AFTER STAPLING. APPLY SEED TO COMPACTED SOIL AND FOLD REMAINING 12" (30cm) PORTION OF BLANKET BACK OVER SEED AND COMPACTED SOIL. SECURE BLANKET OVER COMPACTED SOIL WITH A ROW OF STAPLES/STAKES SPACED APPROXIMATELY 12" (30cm) APART ACROSS THE WIDTH OF THE BLANKET.
 3. ROLL THE BLANKETS (A) DOWN OR (B) HORIZONTALLY ACROSS THE SLOPE. BLANKETS WILL UNROLL WITH APPROPRIATE SIDE AGAINST THE SOIL SURFACE. ALL BLANKETS MUST BE SECURELY FASTENED TO SOIL SURFACE BY PLACING STAPLES/STAKES IN APPROPRIATE LOCATIONS AS SHOWN IN THE STAPLE PATTERN GUIDE. WHEN USING OPTIONAL DOT SYSTEM, STAPLES/STAKES SHOULD BE PLACED THROUGH EACH OF THE COLORED DOTS CORRESPONDING TO THE APPROPRIATE STAPLE PATTERN.
 4. THE EDGES OF PARALLEL BLANKETS MUST BE STAPLED WITH APPROXIMATELY 2"-5" (5cm-12.5cm) OVERLAP DEPENDING ON BLANKET TYPE. TO ENSURE PROPER SEAM ALIGNMENT, PLACE THE EDGE OF THE OVERLAPPING BLANKET (BLANKET BEING INSTALLED ON TOP) EVEN WITH THE COLORED SEAM STITCH ON THE PREVIOUSLY INSTALLED BLANKET.
 5. CONSECUTIVE BLANKETS SPICED DOWN THE SLOPE MUST BE PLACED END OVER END (SHINGLE STYLE) WITH AN APPROXIMATE 3" (7.5cm) OVERLAP. STAPLE THROUGH OVERLAPPED AREA, APPROXIMATELY 12" (30cm) APART ACROSS ENTIRE BLANKET WIDTH.

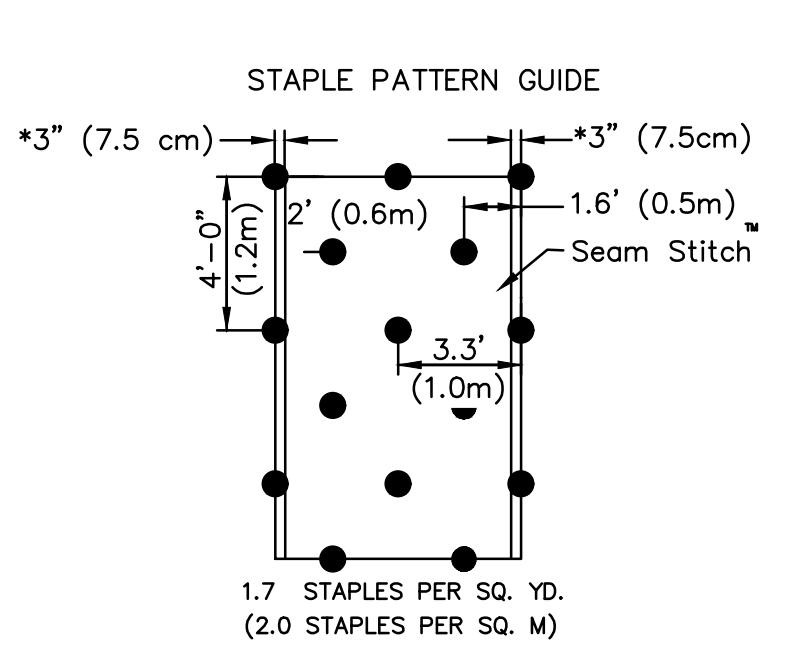

BLANKETS WITH THE OPTIONAL NORTH AMERICAN GREEN DOT SYSTEM PLACE STAPLES/STAKES THROUGH EACH OF THE GREEN COLORED DOTS.

- NOTES:**
- *IN LOOSE SOIL CONDITIONS, THE USE OF STAPLE OR STAKE LENGTHS GREATER THAN 6" (15cm) MAY BE NECESSARY TO PROPERLY SECURE THE BLANKETS.
- CRITICAL POINTS**
- A. OVERLAPS AND SEAMS
 - B. PROJECTED WATER LINE
 - C. CHANNEL BOTTOM/SIDE SLOPE VERTICES
- * HORIZONTAL STAPLE SPACING SHOULD BE ALTERED IF NECESSARY TO ALLOW STAPLES TO SECURE THE CRITICAL POINTS ALONG THE CHANNEL SURFACE.
 - ** IN LOOSE SOIL CONDITIONS, THE USE OF STAPLE OR STAKE LENGTHS IN EXCESS OF 6" (15 cm) MAY BE NECESSARY TO PROPERLY ANCHOR THE BLANKETS.
 - *LOCATION OF SEAM STITCH WILL VARY DEPENDING ON NORTH AMERICAN GREEN PRODUCT TYPE: -APPROX. 5" SEAM OVERLAP FOR BIONET EROSION CONTROL BLANKETS

SLOPE STABILIZATION INSTALLATION
SCALE: NONE
DETAILS\LD\EROSION CONTROL\SLOPE STABILIZATION INSTALLATION.DWG 06/08

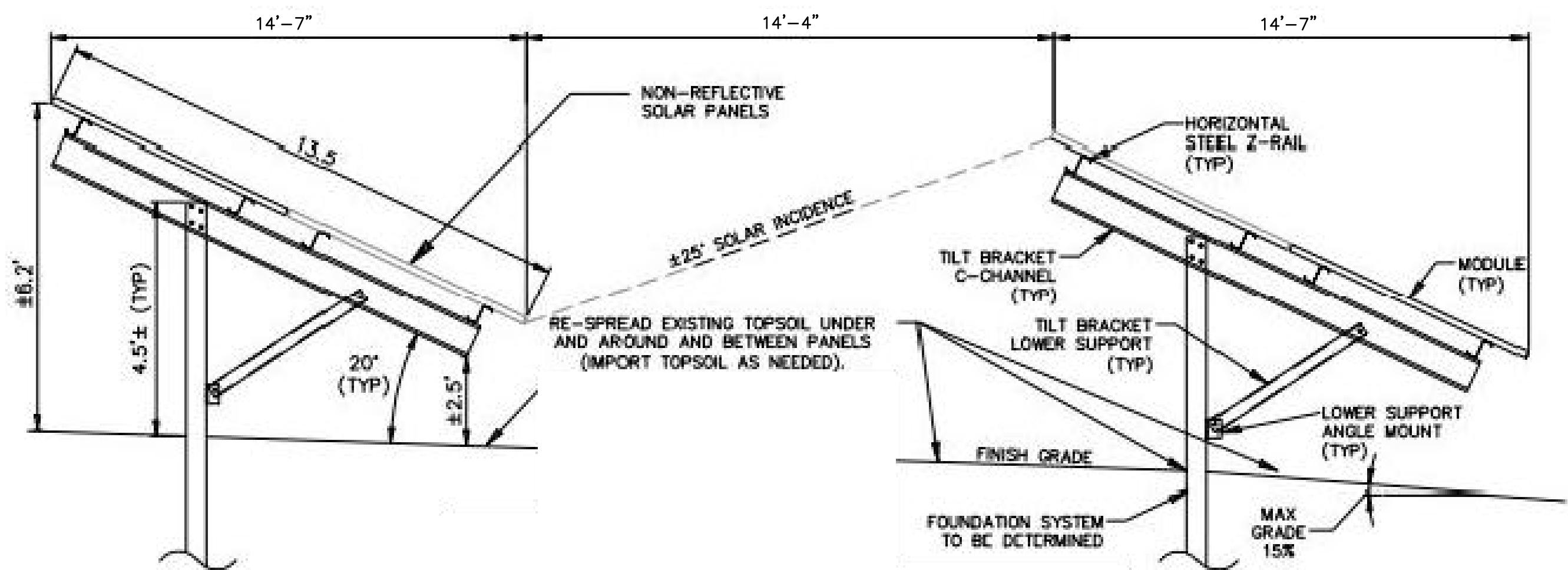

SECTION VIEW - TYPICAL PANEL/RACK ASSEMBLY
SCALE: NONE

CHAIN LINK GATE FRAMEWORK SCHEDULE

GATE LEAF SINGLE WIDTH	6' OR LESS	>6' - <12'
GATE POST	2.875" O.D.	4" O.D.
GATE FRAME (4 SIDES)	2" SQ	2" SQ
INTERIOR UPRIGHT	NONE	1 1/2" SQ

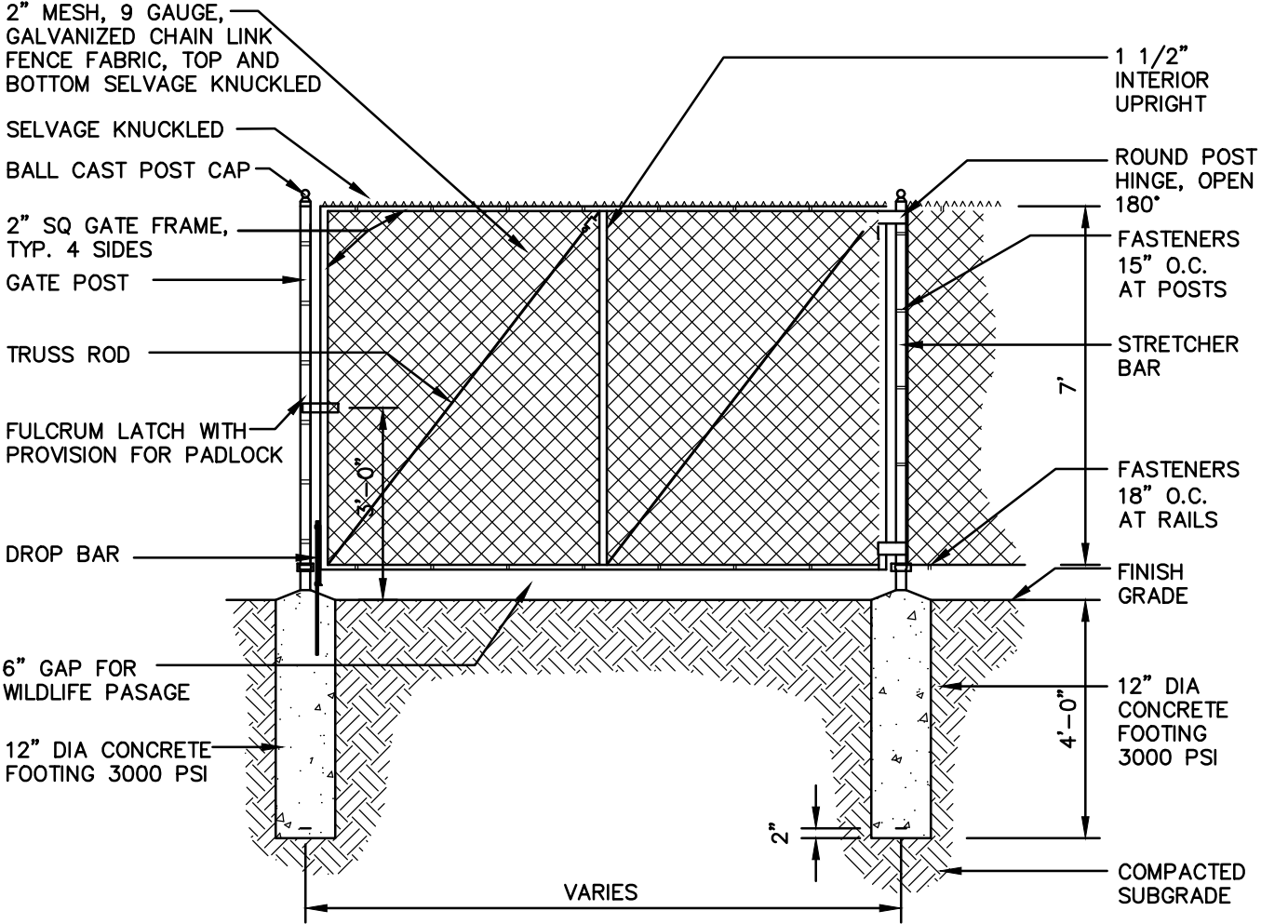

CHAIN LINK FENCE GATE
SCALE: NONE

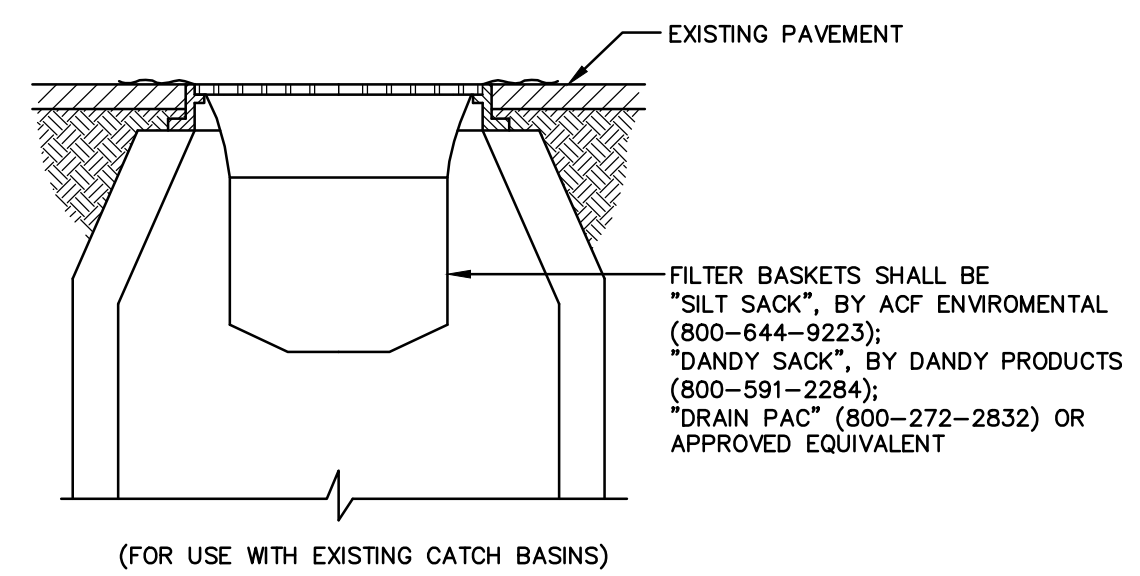

NOTE:
FILTER BASKETS TO BE PLACED IN ALL CATCH BASINS IN THE VICINITY OF NEW CONSTRUCTION. CATCH BASINS ARE TO BE PROTECTED AS SHOWN, WITH MINIMUM WEEKLY MAINTENANCE, OR AS REQUIRED AND REPLACED IF NECESSARY.

SEDIMENT FILTER INLET PROTECTION
SCALE: NONE



BRIAN G. YERGATIAN
PROFESSIONAL ENGINEER
DATE

GROUND-MOUNTED PHOTOVOLTAIC SYSTEM
200 ROUTE 15
IN
STURBRIDGE MASSACHUSETTS (WORCESTER COUNTY)

DETAIL SHEET II

AUGUST 1, 2023

REVISIONS:

NO.	DATE	DESC.
1	11/15/23	PER PEER REVIEW

ISSUED FOR PERMITTING
NOT FOR CONSTRUCTION

PREPARED FOR:
STURBRIDGE PV, LLC
2420 17TH STREET
DENVER, CO 80202

BSC GROUP
349 Main Street - Route 28
West Yarmouth, Massachusetts
02673
508 778 8919

© 2022 BSC Group, Inc.
SCALE: NOT TO SCALE